

# Heller

Catalogue | Catalogue | Katalog

# 2023



ROYAL LOUIS



GENDARMERIE SET RENAULT  
ESTAFETTE + RENAULT 4TL



E-2C HAWKEYE



AVENIR



**VÉHICULES CIVILS**  
CIVILIAN VEHICLES  
ZIVILE FAHRZEUGE

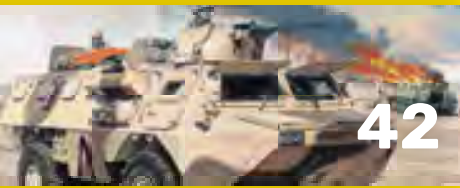

**VÉHICULES MILITAIRES**  
MILITARY VEHICLES  
MILITÄRISCHE FAHRZEUGE



**DIORAMAS**  
DIORAMA  
DIORAMA



**FIGURINES**  
FIGURES  
FIGUREN

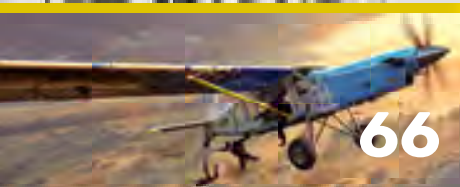

**AVIATION CIVILE**  
CIVIL AVIATION  
ZIVILE LUFTFAHRT

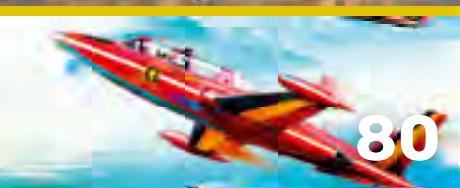

**AVIATION MILITAIRE**  
MILITARY AVIATION  
MILITÄRISCHE LUFTFAHRT



**MARINE CIVILE**  
CIVIL SHIPPING  
ZIVILE SCHIFFFAHRT



**MARINE MILITAIRE**  
MILITARY SHIPPING  
MILITÄRISCHE SCHIFFFAHRT



**VOILIERS**  
SAILING SHIPS  
SEGELSCHIFFE

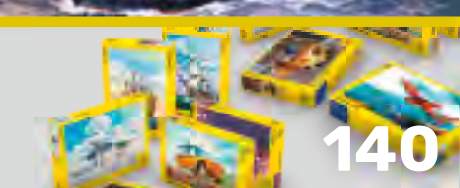

**PUZZLES**  
PUZZLE  
PUZZLE

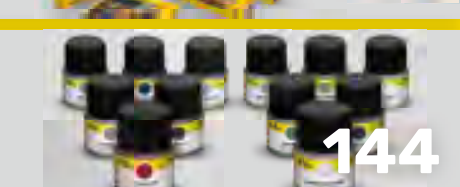

**COULEURS ET PINCEAUX**  
COLOURS AND BRUSHES  
FARBEN UND PINSEL

## BIENVENUE!

Nous sommes heureux de pouvoir présenter, après cinq ans, le catalogue Heller entièrement remanié. Le modélisme est notre passion et avec près de 50 nouveautés prévues, cette année sera un moment fort particulier dans l'histoire de Heller.

## WELCOME!

We are pleased to present the completely new Heller catalogue after five years. Model making is our passion and with almost 50 new products planned, this year will be a special highlight in Heller history.

## WILLKOMMEN!

Wir freuen uns, nach fünf Jahren den komplett neu erstellten Heller Katalog präsentieren zu dürfen. Modellbau ist unsere Leidenschaft und mit fast 50 geplanten Neuheiten wird dieses Jahr ein besonderes Highlight in der Heller Geschichte.

## [FR] QUE SIGNIFIE "VRAIMENT EUROPEËEN" ?

Heller est conçu par une équipe commune de Français et d'Allemands. Nous travaillons de manière transfrontalière, en partenariat et croyons en l'esprit des valeurs européennes communes.

## OÙ SONT FABRIQUÉS LES KITS HELLER ?

La majeure partie de la production de moulage par injection se fait toujours en France. C'est là, à Trun, une ville de Normandie, que Heller a été fondée en 1957. La tradition et l'expertise spécialisée qui s'y trouvent, mais aussi l'important stock de moules Heller sur place en sont la preuve.

## ALORS POURQUOI EST-IL INDIQUÉ "MADE IN GERMANY" SUR LA PLUPART DES KITS HELLER ?

Outre les pièces injectées, un kit Heller comprend de nombreux éléments, tels que la notice de montage, les décalcomanies et l'emballage. Ceux-ci sont produits en France, en Allemagne, en Italie, en République tchèque, en Pologne et dans d'autres pays. Les dernières étapes du travail, l'emballage et l'expédition, ont lieu dans notre entrepôt de Radevormwald/Allemagne. Pour des raisons légales, la plupart des produits portent donc à la fin la mention "Made in Germany", mais ils restent une véritable œuvre collective européenne.

## [EN] WHAT DOES "TRULY EUROPEAN" MEAN?

Heller is designed by a joint team from France and Germany. We work together across borders, in partnership and believe in the spirit of shared European values.

## WHERE ARE HELLER KITS PRODUCED?

Most of the injection moulding production still takes place in France. It was there in Trun, a town in Normandy, that Heller was founded in 1957. This is backed up not only by the tradition and expertise of the specialist luminaire there, but also by the large Heller mould warehouse on site.

## SO WHY DOES IT SAY "MADE IN GERMANY" ON MOST HELLER KITS?

A Heller kit consists of many components in addition to the plastic parts, such as the building instructions, the decals and the packaging. These are produced in France, Germany, Italy, the Czech Republic, Poland and other countries. The last steps, packing and shipping, take place in our

warehouse in Radevormwald/Germany. For legal reasons, therefore, most products end up with the words "Made in Germany", but they remain a genuine European joint effort.

## [DE] WAS BEDEUTET "ECHT EUROPÄISCH"?

Heller wird von einem gemeinsamen Team aus Frankreich und Deutschland gestaltet. Wir arbeiten grenzüberschreitend, partnerschaftlich zusammen und glauben an den Geist gemeinsamer europäischer Werte.

## WO WERDEN HELLER BAUSÄTZE PRODUZIERT?

Der größte Teil der Spritzgussproduktion findet unverändert in Frankreich statt. Dort in Trun, einem Ort in der Normandie, wurde Heller 1957 gegründet. Dafür spricht nicht nur die Tradition und Expertise der Fachleute dort, sondern auch das große Heller Formenlager vor Ort.

## WARUM STEHT AUF DEN MEISTEN HELLER BAUSÄTZEN DANN "MADE IN GERMANY"?

Ein Heller Bausatz besteht neben den Spritzlingen aus vielen Komponenten, wie beispielsweise der Bauanleitung, den Decals und der Verpackung. Diese werden in Frankreich, Deutschland, Italien, Tschechien, Polen und weiteren Ländern produziert. Die letzten Arbeitsschritte, das Verpacken und Versenden, finden in unserem Lager in Radevormwald/Deutschland statt. Aus gesetzlichen Gründen steht daher auf den meisten Produkten am Ende "Made in Germany", doch sie bleiben ein echtes europäisches Gemeinschaftswerk.



# STRUCTURE DU CATALOGUE | CATALOGUE STRUCTURE | KATALOGAUFBAU

**Lien vers le produit sur heller.fr**

Link to the product at heller.fr

Link zum Produkt auf heller.fr

**RENAULT 4 TL/GTL**

REF: 80759

Plus d'informations  
More about this product  
Mehr zu diesem Produkt



REF: 56759  
Starter Kit



**Décalcomanies incluses**

Included waterslide decals

Enthaltene

Nassschiebebilder

**Décorations fournies**

Decorations provide

Enthaltene Decals

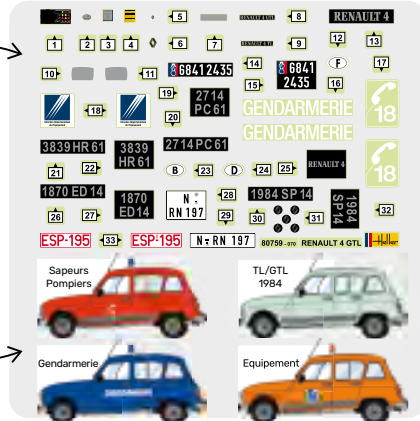

2019 2020

**Année de fabrication du moule**

Year of mould manufacture

Baujahr der Form

**Moule intégralement révisé**

Fully revised mold

Form generalüberholt



**Image du produit**

Product image

Produktbild

**Informations sur l'original**

Information about the original

Informationen zum Original

Année de fabrication Year of construction - Baujahr	1961
Quantité produite Built quantity - Gebaute Menge	8.135.424
Puissance Power - Leistung	34 CV/PS
Vitesse maximale Max. Speed - Max. Geschwindigkeit	122 km/h
Longueur totale Total length - Gesamtlänge	3.67 m

152,8 x 61,9 mm 4 x Decorations provided 124 pieces

**Dimensions du modèle**

Model size

Modellabmessung

**Nombre de pièces**

Number of parts

Anzahl Teile

## LE SAVIEZ-VOUS ? | DID YOU KNOW? | SCHON GEWUSST?



### RECYCLING

**[FR]** Nous produisons de plus en plus de pièces en plastique recyclé. Seules les pièces transparentes et les pièces en caoutchouc sont toujours fabriquées à partir de matériaux neufs. **[EN]** More and more parts are produced by us from recycled plastic. Only clear parts and rubber parts are always made from new material. **[DE]** Immer mehr Teile werden von uns aus Recycling-Kunststoff produziert. Nur Klarteile und Gummitteile werden stets aus neuem Material gefertigt.

### THUMBS UP!

**[FR]** Toutes les dernières informations sont disponibles sur Facebook et Instagram :

**[EN]** All the latest info is on Facebook and Instagram:

**[DE]** Immer die neuesten Infos gibt es auf Facebook und Instagram:



@heller.fr

Download all instructions!



### ONE CLICK

**[FR]** Toutes les instructions de montage peuvent être téléchargées gratuitement sur heller.fr.\* **[EN]** All building instructions can be downloaded free of charge at heller.fr.\* **[DE]** Alle Bauanleitungen können auf heller.fr kostenfrei heruntergeladen werden.\*

\* Ne s'applique pas à / Does not apply to / Gilt nicht für: Le Soleil Royal (80899/58899), Victory (80897/58897)

## OLD BUT GOLD

1980 2020

**[FR]** Certains de nos moules sont déjà un peu plus anciens. Nous le montrons avec fierté sur chaque emballage. En effet, tous les moules ont été retravaillés au mieux et sont au moins aussi bons que l'année de leur première édition. **[EN]** Some of our moulds are already a bit older. We proudly show this on every package. Because all moulds are top revised and are at least as good as in the year of their first edition. **[DE]** Einige unserer Formen sind schon ein bisschen älter. Das zeigen wir auf jeder Verpackung mit Stolz. Denn alle Formen sind top überarbeitet und sind mindestens so gut wie im Jahr ihrer Erstauflage.



## 2300 PIECES

**[FR]** Le Soleil Royal est notre kit qui comprend le plus grand nombre de pièces. Un véritable défi ! **[EN]** Le Soleil Royal is our kit with the most parts. A real challenge! **[DE]** Le Soleil Royal ist unser Bausatz mit den meisten Teilen. Eine wahre Herausforderung!

## 2.5 BILLION

**[FR]** Les six langues présentes sur nos emballages sont la langue maternelle de 2,5 milliards de personnes au total. **[EN]** The six languages on our packaging are the mother tongue of a total of 2.5 billion people. **[DE]** Die sechs Sprachen auf unseren Verpackungen sind die Muttersprache von insgesamt 2,5 Milliarden Menschen.

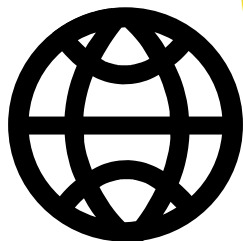

## 80 COUNTRIES

**[FR]** Sur heller.fr, les maquettistes du monde entier peuvent acheter directement tous les kits. **[EN]** At heller.fr, modellers from all over the world can buy all kits directly. **[DE]** Auf heller.fr können Modellbauer aus der ganzen Welt alle Bausätze direkt kaufen.

## 140.000+ VIEWER

**[FR]** Notre Heller News 2023 est un succès sur YouTube. De nombreuses autres vidéos suivront. Scannez ici pour la présentation : **[EN]** Our Heller News 2023 is a YouTube hit. Many more videos will follow. Scan here for the presentation: **[DE]** Unsere Heller News 2023 sind ein YouTube Hit. Viele weitere Videos werden folgen. Hier geht's zur Präsentation:



[bit.ly/HellerNews2023](https://bit.ly/HellerNews2023)





## CETTE MARQUE A UN GRAND AVENIR ! THIS BRAND HAS A GREAT FUTURE! DIESE MARKE HAT EINE GROSSE ZUKUNFT

### **[FR] TROIS QUESTIONS POUR L'ENTREPRENEUR DERRIÈRE HELLER, HEINZ ENGSTFELD.**

**COMMENT VOUS VIENT L'IDÉE DE REPRENDRE UNE MARQUE COMME HELLER ?** Enfant, mon premier modèle réduit était de Heller. Plus tard, j'ai été en contact avec la marque sur le plan professionnel. Avec la création de Glow2B, l'un des principaux grossistes européens de kits de maquettisme, nous sommes également devenus distributeurs de Heller. Lorsqu'il est devenu évident que cette marque légendaire risquait de disparaître du marché, nous avons décidé de lui offrir un nouvel avenir stable. Heller ne pouvait tout simplement pas mourir.

**QUEL EST LE PLUS GRAND DÉFI D'UNE TELLE IDÉE ?** Probablement la multitude de sujets. La production, le marketing, les ventes, la logistique, le service et bien d'autres choses encore - chaque sujet doit être analysé et traité. Cela prend du temps. Parfois plus de temps que je n'en avais la patience [rires]. Sans l'excellente coopération entre anciens et nouveaux collègues, cela n'aurait jamais été possible. Je leur en suis reconnaissant. Il reste encore beaucoup à faire, mais en 2023, nous pourrons enfin nous mettre au travail.

**QUE REPRÉSENTE L'ARRÊT HELLER ET OÙ VA-T-IL ?** Deux choses sont particulièrement importantes pour nous : premièrement, nous voulons être synonyme de plaisir exceptionnel dans le domaine du maquettisme à des prix équitables et deuxièmement, nous voulons toujours être à l'écoute et construire l'avenir avec la grande communauté de fans dans le monde entier. Il s'agit avant tout de beaucoup de plaisir en plus du travail.

### **[EN] THREE QUESTIONS FOR THE ENTREPRENEUR BEHIND HELLER, HEINZ ENGSTFELD.**

**HOW DO YOU COME UP WITH THE IDEA OF TAKING OVER A BRAND LIKE HELLER?** As a child, my first model kit was from Heller. Later I came into contact with the brand professionally. With the founding of Glow2B, one of Europe's leading model kit wholesalers, we also became distributors for Heller. When it became apparent that this legendary brand might disappear from the market, we decided to give it a new, stable future. Heller simply could not die.

**WHAT IS THE BIGGEST CHALLENGE WITH SUCH AN IDEA?** Probably the multitude of topics. Production, marketing, sales, logistics, service and much more - each topic has to be analysed and dealt with. That takes time. Sometimes more time than I had patience for [laughs]. Without the



excellent cooperation between old and new colleagues, this would never have been possible. I am grateful for that. There is still a lot to do, but in 2023 we can finally hit the ground running.

**WHAT DOES HELLER STAND FOR AND WHERE IS IT HEADING?** Two things are particularly important to us: firstly, we want to stand for outstanding pleasure in model building at fair prices and secondly, we always want to listen well and build the future with the large fan community around the world. This is, above all, a lot of fun in addition to the work.

**[DE] DREI FRAGEN AN DEN UNTERNEHMER HINTER HELLER, HEINZ ENGSTFELD.**

**WIE KOMMT MAN AUF DIE IDEE, EINE MARKE WIE HELLER ZU ÜBERNEHMEN?** Als Kind war mein erster Modellbausatz von Heller. Später kam ich beruflich mit der Marke in Kontakt. Mit der Gründung von Glow2B, einem der führenden Modellbaugroßhändler Europas, wurden wir auch Distributeur für Heller. Als sich abzeichnete, dass diese legendäre Marke vom Markt verschwinden könnte, haben wir uns entschieden, ihr eine neue, stabile Zukunft zu geben. Heller durfte einfach nicht sterben.

**WAS IST DIE GRÖSSTE HERAUSFORDERUNG BEI SOLCH EINER IDEE?** Wahrscheinlich die Vielzahl von Themen. Produktion, Marketing, Vertrieb, Logistik, Service und vieles mehr – jedes Thema muss analysiert und bearbeitet werden. Das braucht Zeit. Manchmal mehr Zeit, als ich Geduld hatte [lacht]. Ohne die hervorragende Zusammenarbeit zwischen alten und neuen Kollegen wäre das niemals möglich gewesen. Dafür bin ich dankbar. Es gibt immer noch viel zu tun, aber 2023 können wir endlich voll durchstarten.

**WOFÜR STEHT HELLER UND WOHIN GEHT DER WEG?** Zwei Dinge sind uns besonders wichtig: Erstens wollen wir für herausragende Freude am Modellbau zu fairen Preisen stehen und zweitens wollen wir immer gut zuhören und mit der großen Fangemeinde auf der ganzen Welt an der Zukunft bauen. Das macht neben der Arbeit vor allem auch viel Freude.









Heller

# VÉHICULES CIVILS

CIVILIAN VEHICLES  
ZIVILE FAHRZEUGE

BECHENNEC

# GENDARMERIE SET RENAULT ESTAFETTE + RENAULT 4TL

**[FRANÇAIS]** Dans ce coffret HELLER vous propose les deux véhicules les plus emblématiques de la Gendarmerie Nationale, fortement enracinée dans la mémoire collective. **RENAULT Estafette** C'est ce modèle de base qui équipa la Gendarmerie française dès 1961. Tout d'abord de couleur bleu nuit presque noir, la S'Tafette passera au bleu moyen ou bleu de France en 1969. Les derniers véhicules arrivent dans les unités en 1981, presque en même temps que les premiers RENAULT Trafic. **RENAULT 4TL** Le Gouvernement français choisit la 4L en 1962. Mise en service 1963, qualifiée de révolutionnaire, mais simple d'entretien et économe, elle correspond parfaitement aux demandes de la Gendarmerie. Le modèle de 1978 proposé ici peut compter sur un moteur 1108 cm<sup>3</sup> de 34 ch DIN et une boîte de vitesses à quatre rapports bien étagée. La Gendarmerie déploiera près de 14 000 4L.

**[ENGLISH]** In this set, HELLER offers you the two most famous vehicles of the Gendarmerie Nationale that are most often associated with it. **RENAULT Estafette** The basic model was used by the French Gendarmerie from 1961 onwards, and the S'Tafette was initially produced in midnight blue, almost black, before being changed to medium blue or French blue in 1969. The last vehicles entered the units in 1981, almost at the same time as the first RENAULT Trafic. **RENAULT 4TL** The French government opted for the 4L in 1962. Introduced in 1963, the car was described as revolutionary, but also easy to maintain and economical, and perfectly suited the requirements of the Gendarmerie. The 1978 model proposed here had a 1108 cm<sup>3</sup> engine with 34 DIN hp and a well-matched four-speed gearbox. The Gendarmerie had used almost 14,000 units of the 4L.

**[DEUTSCH]** In diesem Set bietet Ihnen HELLER die beiden bekanntesten Fahrzeuge der Gendarmerie Nationale an, die oft damit in Verbindung gebracht werden. **RENAULT Estafette** Das Basismodell wurde ab 1961 von der französischen Gendarmerie eingesetzt, und der Estafette wurde zunächst in nachtblauer, fast schwarzer Farbe hergestellt, bevor er 1969 auf mittelblau oder französisch blau umgestellt wurde. **RENAULT 4TL** Die französische Regierung entschied sich 1962 für den 4L. Der 1963 vorgestellte Wagen wurde als revolutionär, aber auch als wartungsfreundlich und sparsam beschrieben und entsprach perfekt den Anforderungen der Gendarmerie. Das hier vorgeschlagene Modell aus dem Jahr 1978 verfügte über einen 1108 cm<sup>3</sup>-Motor mit 34 DIN-PS und ein gut abgestuftes Viergang-Getriebe. Die Gendarmerie hatte fast 14.000 Stück des 4L eingesetzt.

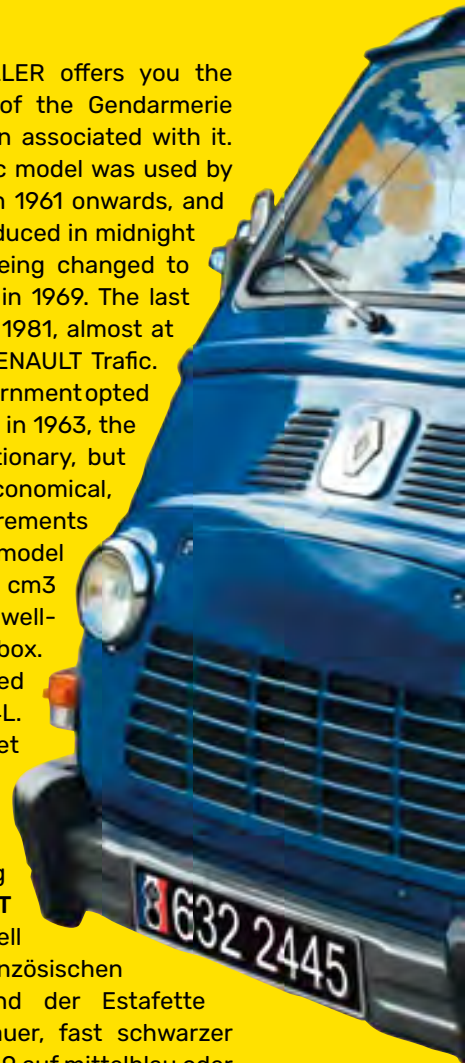

REF: 50325

## GENDARMERIE SET RENAULT ESTAFETTE + RENAULT 4TL

Scale: 1/24

	Renault Estafette	Renault 4TL
<b>Année de fabrication</b> Year of construction • Baujahr	1964 / 1973	1961
<b>Quantité produite</b> Built quantity • Gebaute Menge	500.000	8.135.424
<b>Puissance</b> Power • Leistung	45 CV/PS	34 CV/PS
<b>Vitesse maximale</b> Max. Speed • Max. Geschwindigkeit	90 km/h	122 km/h
<b>Longueur totale</b> Total length • Gesamtlänge	4,1 m	3,67 m

2 x 160 x 74 mm  
152 x 61 mm

167 + 124 pieces

REF: 50325

Plus d'informations  
More about this product  
Mehr zu diesem Produkt



REF: 52325  
Starter Kit



# GENDARMERIE



1984

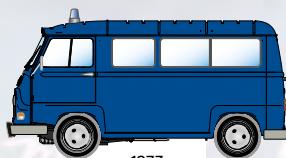

1973



1964

Heller



REF: 80902 **YAMAHA TY 125** Scale: 1/8

<b>Année de fabrication</b> Year of construction • Baujahr	1974
<b>Quantité produite</b> Built quantity • Gebaute Menge	53.000
<b>Puissance</b> Power • Leistung	10 CV/PS
<b>Vitesse maximale</b> Max. Speed • Max. Geschwindigkeit	100 km/h
<b>Longueur totale</b> Total length • Gesamtlänge	1,97 m

247 x 121,8 mm

140 pieces

**YAMAHA TY 125**

REF: 80902  
Plus d'informations  
More about this product  
Mehr zu diesem Produkt



REF: 56902  
Starter Kit

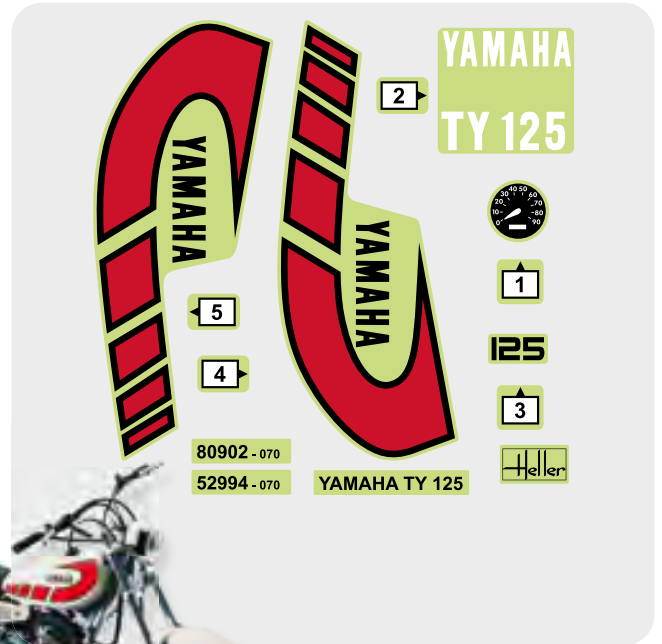

1979 2020

Heller



REF: 80799 **CITROËN 15 SIX TRACTION AVANT** Scale: 1/8

<b>Année de fabrication</b> Year of construction • Baujahr	1938
<b>Quantité produite</b> Built quantity • Gebaute Menge	759.111 (total)
<b>Puissance</b> Power • Leistung	77 CV/PS
<b>Vitesse maximale</b> Max. Speed • Max. Geschwindigkeit	130 km/h
<b>Longueur totale</b> Total length • Gesamtlänge	4,80 m

595 x 220 mm

1054 pieces

**CITROËN 15 SIX TRACTION AVANT**

REF: 80799  
Plus d'informations  
More about this product  
Mehr zu diesem Produkt



REF: 56799  
Starter Kit



1977 2021

## CITROËN DS 19 BERLINE

REF: 80795  
Plus d'informations  
More about this product  
Mehr zu diesem Produkt



REF: 56795  
Starter Kit



5249 HU 75

1

5249 HU 75

2

8935·FB·75

1

8935·FB·75

2

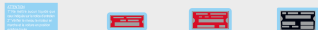

6

4

5

3



8



7

80795 - 170

CITROËN DS19 BERLINE



1984 2021

## CITROËN DS19 CABRIOLET

REF: 80796  
Plus d'informations  
More about this product  
Mehr zu diesem Produkt



REF: 56796  
Starter Kit



2127 W 16

1

2127 W 16

2

5664·PT·75

1

5664·PT·75

2



6

4

5

3



8



7

80796 - 070

CITROËN DS19 CABRIOLET

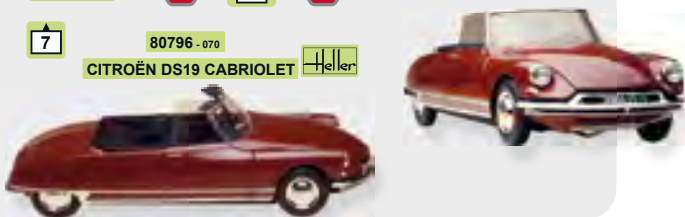

1985 2021



REF: 80795

CITROËN DS 19  
BERLINE

Scale: 1/16

<b>Année de fabrication</b> Year of construction · Baujahr	1960
<b>Quantité produite</b> Built quantity · Gebaute Menge	1.455.746
<b>Puissance</b> Power · Leistung	75 CV/PS
<b>Vitesse maximale</b> Max. Speed · Max. Geschwindigkeit	150 km/h
<b>Longueur totale</b> Total length · Gesamtlänge	4,83 m

298 x 111 mm

157 pieces



REF: 80796

CITROËN DS19  
CABRIOLET

Scale: 1/16

<b>Année de fabrication</b> Year of construction · Baujahr	1960
<b>Quantité produite</b> Built quantity · Gebaute Menge	1 455 746
<b>Puissance</b> Power · Leistung	75 CV/PS
<b>Vitesse maximale</b> Max. Speed · Max. Geschwindigkeit	150 km/h
<b>Longueur totale</b> Total length · Gesamtlänge	4,83 m

298 x 111 mm

168 pieces

Heller



REF: 30705

**RENAULT TAXI TYPE AG**

Scale: 1/24

<b>Année de fabrication</b> Year of construction · Baujahr	1907
<b>Quantité produite</b> Built quantity · Gebaute Menge	10.000
<b>Puissance</b> Power · Leistung	10 CV/PS
<b>Vitesse maximale</b> Max. Speed · Max. Geschwindigkeit	45 km/h
<b>Longueur totale</b> Total length · Gesamtlänge	3,75 m

156 x 65 mm 108 pieces

**RENAULT TAXI TYPE AG**

**REF: 30705**  
Plus d'informations  
More about this product  
Mehr zu diesem Produkt



**REF: 35705**  
Starter Kit



**598 G7** **598 G7**

**1129 - G7** **1129 - G7**

**3192 - G 7** **3192 - G 7**

LEVALLOIS **598 G7** **598 G7** LEVALLOIS **libre**

30705 **RENAULT Taxi Type AG**



Heller



REF: 80702

**CITROËN 5CV TRÈFLE**

Scale: 1/24

<b>Année de fabrication</b> Year of construction · Baujahr	1922
<b>Quantité produite</b> Built quantity · Gebaute Menge	80.250
<b>Puissance</b> Power · Leistung	11 CV/PS
<b>Vitesse maximale</b> Max. Speed · Max. Geschwindigkeit	60 km/h
<b>Longueur totale</b> Total length · Gesamtlänge	3,25 m

135 x 53 mm 102 pieces

**CITROËN 5CV TRÈFLE**

**REF: 80702**  
Plus d'informations  
More about this product  
Mehr zu diesem Produkt



**REF: 56702**  
Starter Kit



**1924.C3T3** **6342 - E 7**

**1924.C3T3** **6342-E7**

**80702 - 170** **CITROEN 5CV TREFLE**



**1978** **2021**

## CITROËN C4 FOURGONNETTE 1928

REF: 80703  
Plus d'informations  
More about this product  
Mehr zu diesem Produkt



REF: 56703  
Starter Kit



3452-R-6 3 3452-R-6

CITROEN C4 1928 4 CITROEN C4 1928



1

2



80703 - 170 CITROËN C4 Fourgonnette 1928

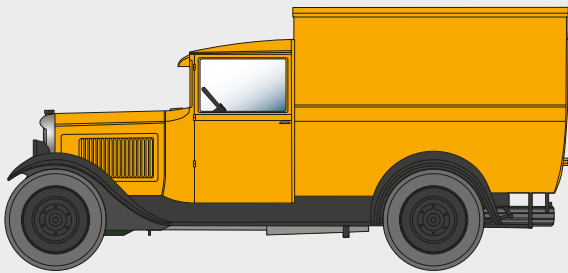

1982 2021

## CITROËN B14 NORMANDE

REF: 80729  
Plus d'informations  
More about this product  
Mehr zu diesem Produkt



REF: 56729  
Starter Kit



2958 RE 7 3 2958 RE 7

950 CT 2 4 950 CT 2

1890 CB 6 5 1890 CB 6



1

2



CITROËN B14  
NORMANDE



80729



1985 2021



REF: 80703

### CITROËN C4 FOURGONNETTE 1928

Scale: 1/24

<b>Année de fabrication</b> Year of construction - Baujahr	1928
<b>Quantité produite</b> Built quantity - Gebaute Menge	121.000
<b>Puissance</b> Power - Leistung	32 CV/PS
<b>Vitesse maximale</b> Max. Speed - Max. Geschwindigkeit	90 km/h
<b>Longueur totale</b> Total lenght - Gesamtlänge	4,18 m

175 x 66 mm

106 pieces



REF: 80729

### CITROËN B14 NORMANDE

Scale: 1/24

<b>Année de fabrication</b> Year of construction - Baujahr	1926
<b>Quantité produite</b> Built quantity - Gebaute Menge	8933
<b>Puissance</b> Power - Leistung	21 CV/PS
<b>Vitesse maximale</b> Max. Speed - Max. Geschwindigkeit	80 km/h
<b>Longueur totale</b> Total lenght - Gesamtlänge	4,15 m

173 x 62 mm

83 pieces



REF: 80713

**CITROËN C4  
SPLENDID HÔTEL**

Scale: 1/24

<b>Année de fabrication</b> Year of construction · Baujahr	1928
<b>Quantité produite</b> Built quantity · Gebaute Menge	121.000
<b>Puissance</b> Power · Leistung	32 CV/PS
<b>Vitesse maximale</b> Max. Speed · Max. Geschwindigkeit	90 km/h
<b>Longueur totale</b> Total length · Gesamtlänge	4.20 m

175 x 66 mm

106 pieces



**CITROËN C4 SPLENDID HÔTEL**

**REF: 80713**  
Plus d'informations  
More about this product  
Mehr zu diesem Produkt



**REF: 56713**  
Starter Kit

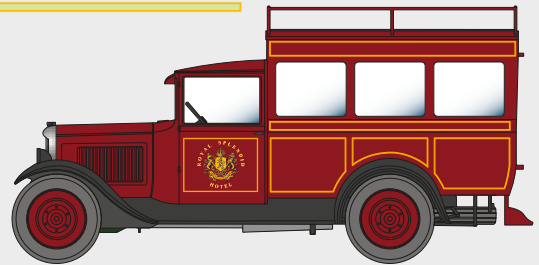

1982 2020



REF: 80706

**BUGATTI T50**

Scale: 1/24

<b>Année de fabrication</b> Year of construction · Baujahr	1931
<b>Quantité produite</b> Built quantity · Gebaute Menge	65 (total)
<b>Puissance</b> Power · Leistung	200 CV/PS
<b>Vitesse maximale</b> Max. Speed · Max. Geschwindigkeit	175 km/h
<b>Longueur totale</b> Total length · Gesamtlänge	5,00 m

211 x 72 mm

150 pieces

**BUGATTI T50**

**REF: 80706**  
Plus d'informations  
More about this product  
Mehr zu diesem Produkt



**REF: 56706**  
Starter Kit

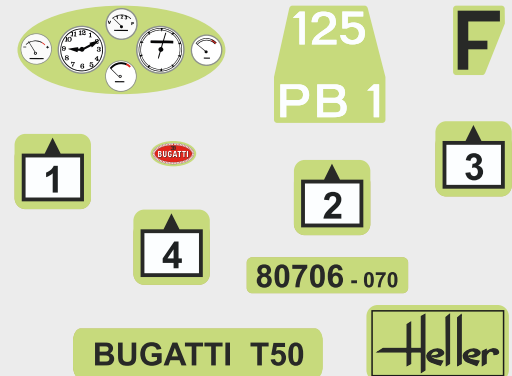

1978 2020



## MERCEDES 500 K SPECIAL ROADSTER

REF: 80710  
Plus d'informations  
More about this product  
Mehr zu diesem Produkt



REF: 56710  
Starter Kit

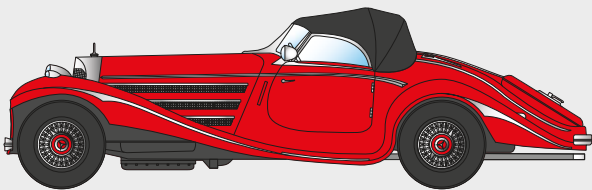
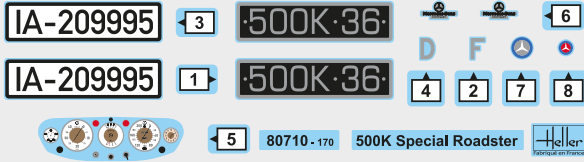

1979 2021

## CITROËN 15 CV

REF: 80763  
Plus d'informations  
More about this product  
Mehr zu diesem Produkt



REF: 56763  
Starter Kit

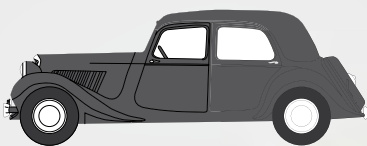
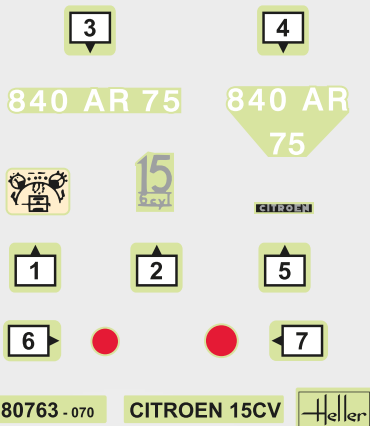

1978 2020



REF: 80710

### MERCEDES 500 K SPECIAL ROADSTER

Scale: 1/24

<b>Année de fabrication</b> Year of construction • Baujahr	1934
<b>Quantité produite</b> Built quantity • Gebaute Menge	342
<b>Puissance</b> Power • Leistung	100 CV/PS
<b>Vitesse maximale</b> Max. Speed • Max. Geschwindigkeit	160 km/h
<b>Longueur totale</b> Total length • Gesamtlänge	5,15 m

218 x 78 mm

122 pieces



REF: 80763

### CITROËN 15 CV

Scale: 1/24

<b>Année de fabrication</b> Year of construction • Baujahr	1938
<b>Quantité produite</b> Built quantity • Gebaute Menge	759.111 (total)
<b>Puissance</b> Power • Leistung	77 CV/PS
<b>Vitesse maximale</b> Max. Speed • Max. Geschwindigkeit	130 km/h
<b>Longueur totale</b> Total length • Gesamtlänge	4,80 m

195 x 72 mm

160 pieces

Heller



REF: 80711 **TALBOT LAGO RECORD** Scale: 1/24

<b>Année de fabrication</b> Year of construction • Baujahr	1950
<b>Quantité produite</b> Built quantity • Gebaute Menge	750
<b>Puissance</b> Power • Leistung	170 CV/PS
<b>Vitesse maximale</b> Max. Speed • Max. Geschwindigkeit	200 km/h
<b>Longueur totale</b> Total length • Gesamtlänge	5,05 m

217 x 76 mm

124 pieces

## TALBOT LAGO RECORD

REF: 80711  
Plus d'informations  
More about this product  
Mehr zu diesem Produkt



REF: 56711  
Starter Kit

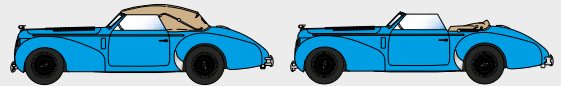
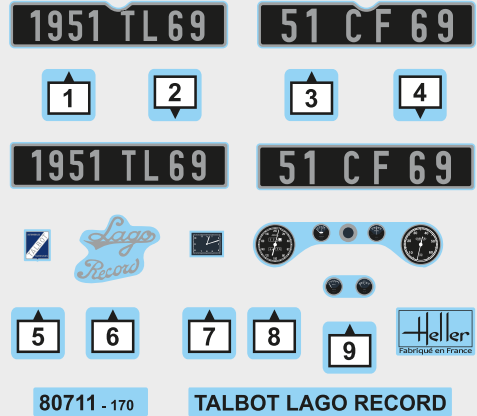

1979 2021

Heller



REF: 80762 **RENAULT 4 CV** Scale: 1/24

<b>Année de fabrication</b> Year of construction • Baujahr	1954
<b>Quantité produite</b> Built quantity • Gebaute Menge	1.105.547
<b>Puissance</b> Power • Leistung	35 CV/PS
<b>Vitesse maximale</b> Max. Speed • Max. Geschwindigkeit	122 km/h
<b>Longueur totale</b> Total length • Gesamtlänge	3,63 m

151 x 60 mm

86 pieces

## RENAULT 4 CV

REF: 80762  
Plus d'informations  
More about this product  
Mehr zu diesem Produkt



REF: 56762  
Starter Kit

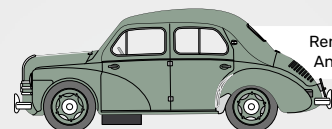
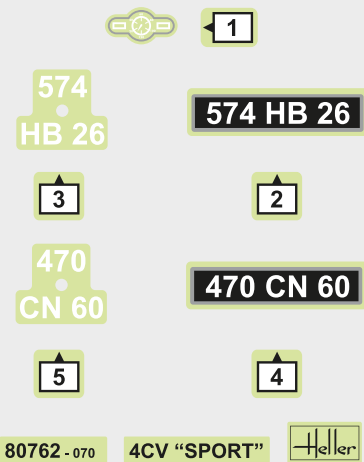

Renault 4 CV "Sport",  
Année modèle 1955

1982 2020

## JAGUAR TYPE E 3L8 FHC

REF: 80709  
Plus d'informations  
More about this product  
Mehr zu diesem Produkt



REF: 56709  
Starter Kit



1961 TG 75 1 1961 TG 75



4 80709-170

JAGUAR TYPE E 3L8 FHC



1978 2020

## RENAULT 4 TL/GTL

REF: 80759  
Plus d'informations  
More about this product  
Mehr zu diesem Produkt



REF: 56759  
Starter Kit

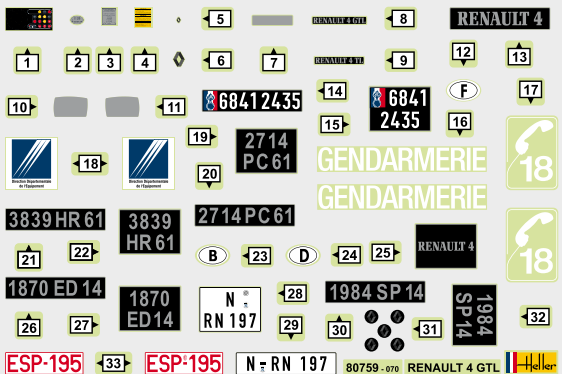

2015 2020



REF: 80709

JAGUAR  
TYPE E 3L8 FHC

Scale: 1/24

<b>Année de fabrication</b> Year of construction • Baujahr	1961
<b>Quantité produite</b> Built quantity • Gebaute Menge	up to 72.500 (all versions)
<b>Puissance</b> Power • Leistung	265 CV/PS
<b>Vitesse maximale</b> Max. Speed • Max. Geschwindigkeit	255 km/h
<b>Longueur totale</b> Total length • Gesamtlänge	4,37 m

185 x 98 mm

85 pieces



REF: 80759

RENAULT 4 TL/GTL

Scale: 1/24

<b>Année de fabrication</b> Year of construction • Baujahr	1961
<b>Quantité produite</b> Built quantity • Gebaute Menge	8.135.424
<b>Puissance</b> Power • Leistung	34 CV/PS
<b>Vitesse maximale</b> Max. Speed • Max. Geschwindigkeit	122 km/h
<b>Longueur totale</b> Total length • Gesamtlänge	3,67 m

152,8 x 61,9 mm

4 x Decorations provided

124 pieces

Heller



REF: 80760

**CITROËN MEHARI**

Scale: 1/24

<b>Année de fabrication</b> Year of construction • Baujahr	1968
<b>Quantité produite</b> Built quantity • Gebaute Menge	144.953
<b>Puissance</b> Power • Leistung	29 CV/PS
<b>Vitesse maximale</b> Max. Speed • Max. Geschwindigkeit	110 km/h
<b>Longueur totale</b> Total length • Gesamtlänge	3,50 m

145 x 63 mm

124 pieces



**CITROËN MEHARI**

REF: 80760  
Plus d'informations  
More about this product  
Mehr zu diesem Produkt



REF: 56760  
Starter Kit



DH - 822 - QL

BV - 648 - DE

1

F

10

3

64

9

DH - 822 - QL

2

4

BV - 648 - DE

5

7

BF - 861 - EZ

856 VM 61

BF - 861 - EZ

6

856 VM 61

11

8

80760-070

CITROËN MEHARI



**2015** **2021**

Heller

**PREVIEW**

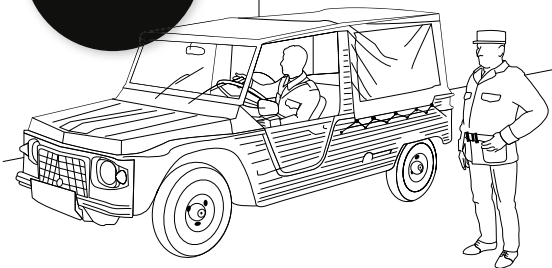

REF: 82702

**CITROËN MEHARI GENDARMERIE**

Scale: 1/24

<b>Année de fabrication</b> Year of construction • Baujahr	1968
<b>Quantité produite</b> Built quantity • Gebaute Menge	144 953
<b>Puissance</b> Power • Leistung	29 CV/PS
<b>Vitesse maximale</b> Max. Speed • Max. Geschwindigkeit	110 km/h
<b>Longueur totale</b> Total length • Gesamtlänge	3,50 m

145 x 63 mm

2x 73 mm

124 pieces

**CITROËN MEHARI GENDARMERIE**

REF: 82702  
Plus d'informations  
More about this product  
Mehr zu diesem Produkt



REF: 58702  
Starter Kit



**NEW PARTS**



**2023** **2015** **2021**

## CITROËN 2CV

REF: 80765  
Plus d'informations  
More about this product  
Mehr zu diesem Produkt



REF: 56765  
Starter Kit

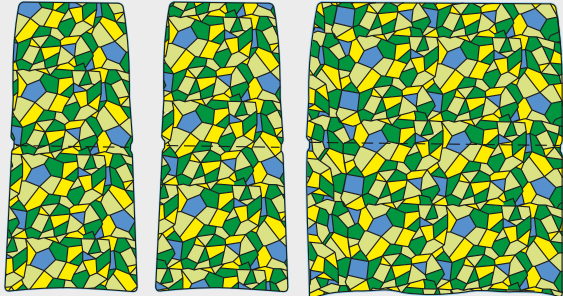

1991 2020

## CITROËN 2CV CHARLESTON

REF: 80766  
Plus d'informations  
More about this product  
Mehr zu diesem Produkt



REF: 56766  
Starter Kit

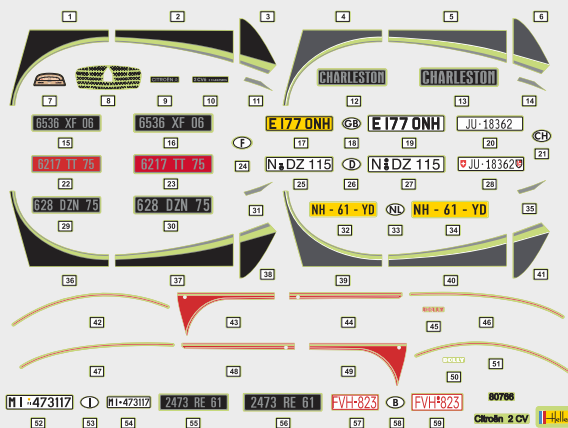

Charleston rouge  
Delage



Charleston gris  
Cormoran

Charleston jaune  
Héliosb



Dolly



1991 2020



REF: 80765

### CITROËN 2CV

Scale: 1/24

<b>Année de fabrication</b> Year of construction • Baujahr	1980
<b>Quantité produite</b> Built quantity • Gebaute Menge	5.114.961 (total 2CV)
<b>Puissance</b> Power • Leistung	29 CV/PS
<b>Vitesse maximale</b> Max. Speed • Max. Geschwindigkeit	120 km/h
<b>Longueur totale</b> Total length • Gesamtlänge	3,83 m

159 x 61 mm

99 pieces



REF: 80766

### CITROËN 2CV CHARLESTON

Scale: 1/24

<b>Année de fabrication</b> Year of construction • Baujahr	1980
<b>Quantité produite</b> Built quantity • Gebaute Menge	5.114.961 (total 2CV)
<b>Puissance</b> Power • Leistung	29 CV/PS
<b>Vitesse maximale</b> Max. Speed • Max. Geschwindigkeit	120 km/h
<b>Longueur totale</b> Total length • Gesamtlänge	3,83 m

159 x 61 mm

4 x Decorations provided

99 pieces

Heller



REF: 80738

**BUGATTI EB 110**

Scale: 1/24

<b>Année de fabrication</b> Year of construction • Baujahr	1991
<b>Quantité produite</b> Built quantity • Gebaute Menge	139
<b>Puissance</b> Power • Leistung	553 CV/PS
<b>Vitesse maximale</b> Max. Speed • Max. Geschwindigkeit	344 km/h
<b>Longueur totale</b> Total length • Gesamtlänge	4,40 m

183 x 83 mm

84 pieces

**BUGATTI EB 110**

REF: 80738  
Plus d'informations  
More about this product  
Mehr zu diesem Produkt



REF: 56738  
Starter Kit

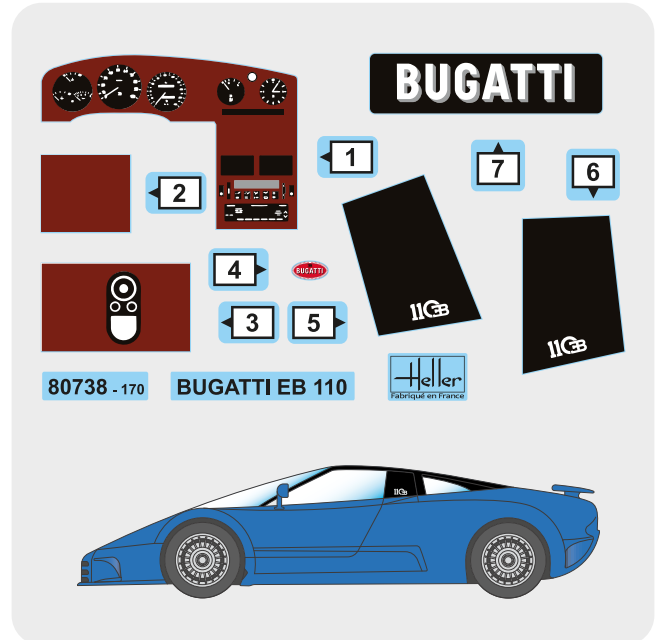

1992 2021

Heller



REF: 80722

**BENTLEY  
4,5 L BLOWER**

Scale: 1/24

<b>Année de fabrication</b> Year of construction • Baujahr	1930
<b>Quantité produite</b> Built quantity • Gebaute Menge	55
<b>Puissance</b> Power • Leistung	240 CV/PS
<b>Vitesse maximale</b> Max. Speed • Max. Geschwindigkeit	222 km/h
<b>Longueur totale</b> Total length • Gesamtlänge	4,44 m

183 x 71 mm

126 pieces

**BENTLEY 4,5 L BLOWER**

REF: 80722  
Plus d'informations  
More about this product  
Mehr zu diesem Produkt



REF: 56722  
Starter Kit

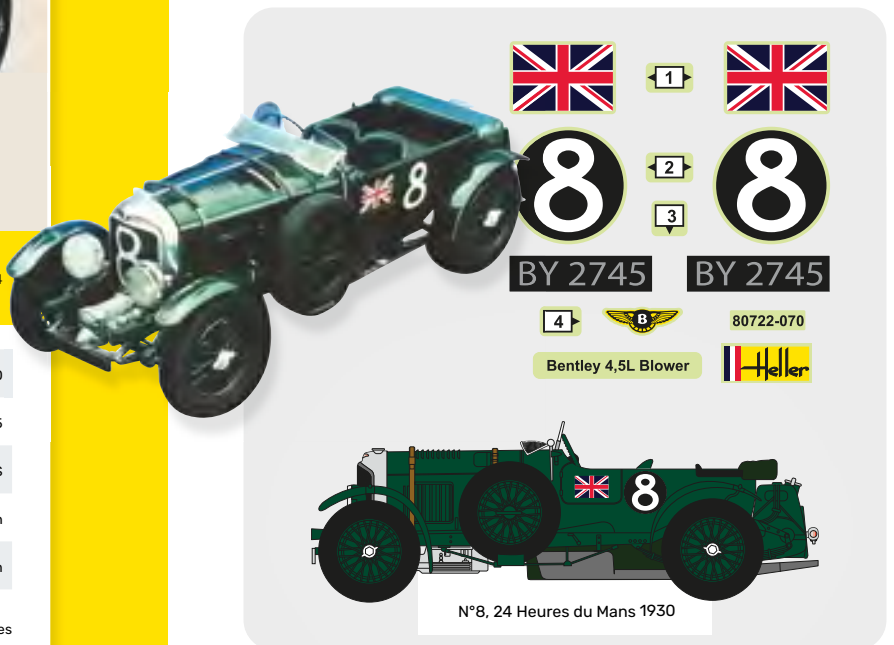

N°8, 24 Heures du Mans 1930

1978 2021

## BMW 328 ENDURANCE

REF: 80782  
Plus d'informations  
More about this product  
Mehr zu diesem Produkt



REF: 56782  
Starter Kit



80782 - 170  
BMW 328 Endurance  
Heller  
fabrique en France

1987 2020

## TALBOT LAGO GRAND PRIX

REF: 80721  
Plus d'informations  
More about this product  
Mehr zu diesem Produkt



REF: 56721  
Starter Kit



80721 - 170  
TALBOT LAGO GP  
Heller  
fabrique en France

1979 2021



REF: 80782

### BMW 328 ENDURANCE

Scale: 1/24

<b>Année de fabrication</b> Year of construction - Baujahr	1936
<b>Quantité produite</b> Built quantity - Gebaute Menge	462
<b>Puissance</b> Power - Leistung	80 CV/PS
<b>Vitesse maximale</b> Max. Speed - Max. Geschwindigkeit	165 km/h
<b>Longueur totale</b> Total length - Gesamtlänge	3,90 m

157 x 63 mm

94 pieces



REF: 80721

### TALBOT LAGO GRAND PRIX

Scale: 1/24

<b>Année de fabrication</b> Year of construction - Baujahr	1950
<b>Quantité produite</b> Built quantity - Gebaute Menge	23
<b>Puissance</b> Power - Leistung	270 CV/PS
<b>Vitesse maximale</b> Max. Speed - Max. Geschwindigkeit	280 km/h
<b>Longueur totale</b> Total length - Gesamtlänge	4,03 m

168 x 69 mm

2 x Decorations provided

86 pieces

Heller



REF: 80700 **RENAULT R8 GORDINI** Scale: 1/24

<b>Année de fabrication</b> Year of construction • Baujahr	1964
<b>Quantité produite</b> Built quantity • Gebaute Menge	8.981
<b>Puissance</b> Power • Leistung	103 CV/PS
<b>Vitesse maximale</b> Max. Speed • Max. Geschwindigkeit	175 km/h
<b>Longueur totale</b> Total length • Gesamtlänge	3,99 m

165 x 63 mm      2 x Decorations provided      117 pieces

**RENAULT R8 GORDINI**

**REF: 80700**  
Plus d'informations  
More about this product  
Mehr zu diesem Produkt



**REF: 56700**  
Starter Kit

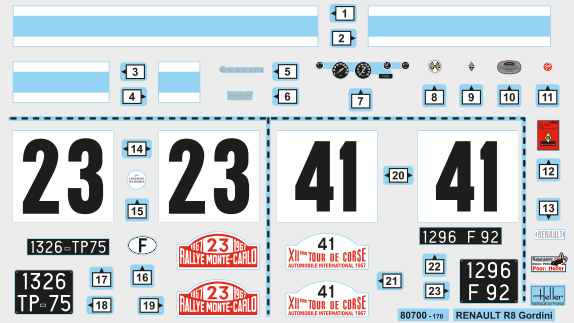

N° 23 - 7ème - Jean-François PIOT / Michel KARAKY - Rallye Monte Carlo 1967



N° 41 - 7ème - Jean-Pierre NICOLAS / Claude ROURE - Tour de Corse 1967



1968 2021

Heller



REF: 80745 **ALPINE A110 1600 S** Scale: 1/24

<b>Année de fabrication</b> Year of construction • Baujahr	1973
<b>Quantité produite</b> Built quantity • Gebaute Menge	7.176
<b>Puissance</b> Power • Leistung	165 CV/PS
<b>Vitesse maximale</b> Max. Speed • Max. Geschwindigkeit	215 km/h
<b>Longueur totale</b> Total length • Gesamtlänge	3,80 m

157 x 68 mm      2 x Decorations provided      139 pieces

**ALPINE A110 1600 S**

**REF: 80745**  
Plus d'informations  
More about this product  
Mehr zu diesem Produkt



**REF: 56745**  
Starter Kit



No. 1 - 1st - Jean-Pierre Nicolas / Michel Vial - Tour de Corse 1973

No. 18 - 1st - Jean-Claude Andruet / "Biche" (Michèle Espinosi-Petit) - Rallye Monte Carlo 1973



1974 2020



## PEUGEOT 205 EV 2

REF: 80716  
Plus d'informations  
More about this product  
Mehr zu diesem Produkt



REF: 56716  
Starter Kit



No. 5 - 30. Tour de Corse.  
B.Saby / J.F. Fauchille



1985 2020

## RENAULT R5 TURBO

REF: 80717  
Plus d'informations  
More about this product  
Mehr zu diesem Produkt



REF: 56717  
Starter Kit

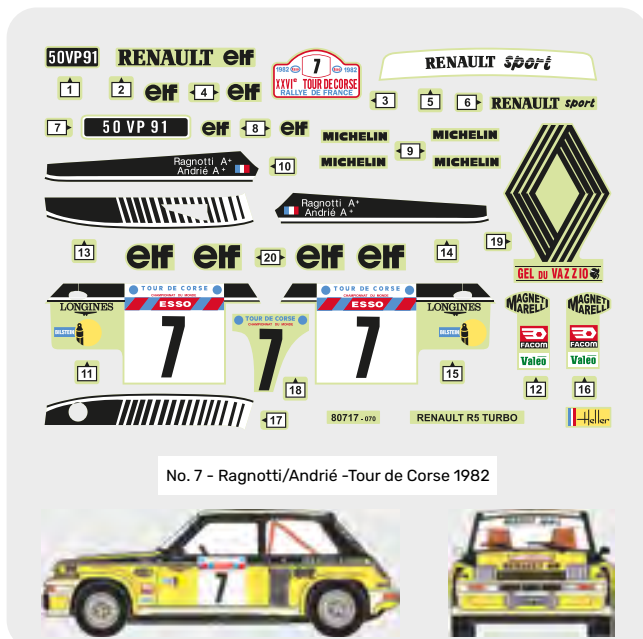

No. 7 - Ragnotti/Andrié - Tour de Corse 1982



1983 2020



REF: 80716 PEUGEOT 205 EV 2 Scale: 1/24

<b>Année de fabrication</b> Year of construction • Baujahr	1983
<b>Quantité produite</b> Built quantity • Gebaute Menge	200
<b>Puissance</b> Power • Leistung	430 CV/PS
<b>Vitesse maximale</b> Max. Speed • Max. Geschwindigkeit	214 km/h
<b>Longueur totale</b> Total length • Gesamtlänge	3,82 m

161 x 70 mm 41 pieces



REF: 80717 RENAULT R5 TURBO Scale: 1/24

<b>Année de fabrication</b> Year of construction • Baujahr	1980
<b>Quantité produite</b> Built quantity • Gebaute Menge	4.857
<b>Puissance</b> Power • Leistung	160 CV/PS
<b>Vitesse maximale</b> Max. Speed • Max. Geschwindigkeit	204 km/h
<b>Longueur totale</b> Total length • Gesamtlänge	3,66 m

161 x 70 mm 39 pieces



REF: 80718 **PEUGEOT 905 EV 1** Scale: 1/24

<b>Année de fabrication</b> Year of construction • Baujahr	1990
<b>Quantité produite</b> Built quantity • Gebaute Menge	9
<b>Puissance</b> Power • Leistung	650 CV/PS
<b>Vitesse maximale</b> Max. Speed • Max. Geschwindigkeit	280 km/h
<b>Longueur totale</b> Total length • Gesamtlänge	4,80 m

201 x 83 mm      2 x Decorations provided      99 pieces

## PEUGEOT 905 EV 1

**REF: 80718**  
Plus d'informations  
More about this product  
Mehr zu diesem Produkt



**REF: 56718**  
Starter Kit

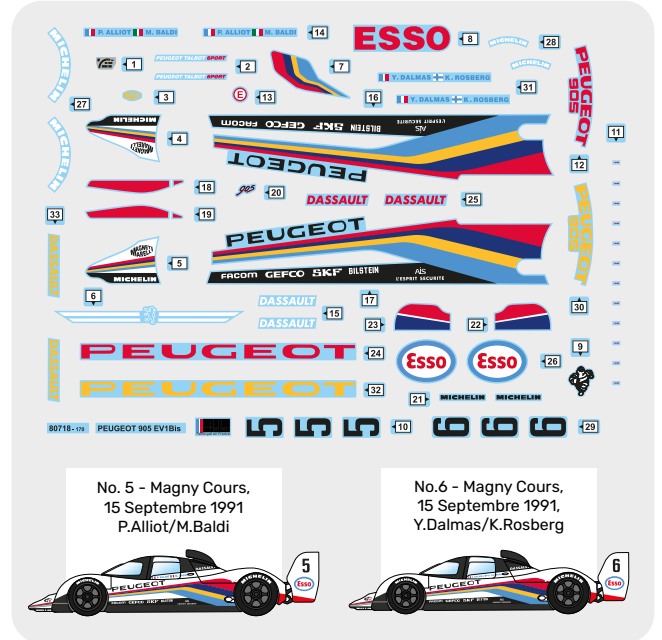

1991 2021



REF: 80758 **CITROËN DS3 WRC** Scale: 1/24

<b>Année de fabrication</b> Year of construction • Baujahr	2013
<b>Quantité produite</b> Built quantity • Gebaute Menge	/
<b>Puissance</b> Power • Leistung	275 CV / PS
<b>Vitesse maximale</b> Max. Speed • Max. Geschwindigkeit	ca. 240 km/h
<b>Longueur totale</b> Total length • Gesamtlänge	3,94 m

180 x 75 mm      66 pieces

## CITROËN DS3 WRC

**REF: 80758**  
Plus d'informations  
More about this product  
Mehr zu diesem Produkt



**REF: 56758**  
Starter Kit



2012 2023

## GORDINI RACING SET

REF: 50328  
Plus d'informations  
More about this product  
Mehr zu diesem Produkt



REF: 52328  
Starter Kit



**NEW**

2021 2023 1968 2021



REF: 50328 **GORDINI RACING SET** Scale: 1/24

	ESTAFETTE HIGHROOF	CAR TRANSPORTER TRAILER	RENAULT 8B GORDINI
<b>Année de fabrication</b> Year of construction • Baujahr	1964	1976	1964
<b>Quantité produite</b> Built quantity • Gebaute Menge	500.000	/	8.981
<b>Puissance</b> Power • Leistung	45 CV / PS	/	103 CV / PS
<b>Vitesse maximale</b> Max. Speed • Max. Geschwindigkeit	90 km/h	80 km/h	175 km/h
<b>Longueur totale</b> Total length • Gesamtlänge	4,1 m	5,98 m	3,99 m

3 x 160 x 74 mm  
254 x 94 mm  
165 x 63 mm

2 x Decorations provided

159 + 86 + 117 pieces

## MERCEDES 170 V LIEFERWAGEN

REF: 80736  
Plus d'informations  
More about this product  
Mehr zu diesem Produkt



REF: 56736  
Starter Kit



170 V Lieferwagen  
80736-170

1128 CM 75  
1128 CM 75

H70-4832  
H70-4832

Prinz Obst & Gemüse,  
Frankfurt/Main, Allemagne

Fruits-Primeurs,  
Paris, France

1979 2020



REF: 80736 **MERCEDES 170 V LIEFERWAGEN** Scale: 1/24

<b>Année de fabrication</b> Year of construction • Baujahr	1950
<b>Quantité produite</b> Built quantity • Gebaute Menge	100.000
<b>Puissance</b> Power • Leistung	44 CV/PS
<b>Vitesse maximale</b> Max. Speed • Max. Geschwindigkeit	100 km/h
<b>Longueur totale</b> Total length • Gesamtlänge	4,37 m

175 x 68 mm

2 x Decorations provided

80 pieces

Heller

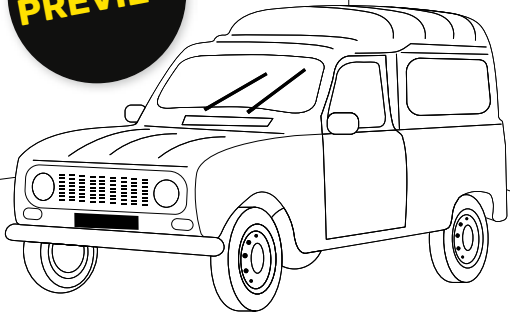

PREVIEW

**RENAULT 4  
FOURGONNETTE F4**

REF: 82700 Scale: 1/24

<b>Année de fabrication</b> Year of construction · Baujahr	1984
<b>Quantité produite</b> Built quantity · Gebaute Menge	8 135 424 (all)
<b>Puissance</b> Power · Leistung	34 CV/PS
<b>Vitesse maximale</b> Max. Speed · Max. Geschwindigkeit	123 km/h
<b>Longueur totale</b> Total length · Gesamtlänge	3,65 m

152 x 62 mm 2 x Decorations provided

## RENAULT 4 FOURGONNETTE F4

**REF: 82700**  
Plus d'informations  
More about this product  
Mehr zu diesem Produkt



**REF: 58700**  
Starter Kit



2023

Heller



PREVIEW

**CITROËN 2CV  
FOURGONNETTE AK 250**

REF: 82701 Scale: 1/24

<b>Année de fabrication</b> Year of construction · Baujahr	1963
<b>Quantité produite</b> Built quantity · Gebaute Menge	1 246 335 (all)
<b>Puissance</b> Power · Leistung	29 CV / PS
<b>Vitesse maximale</b> Max. Speed · Max. Geschwindigkeit	120 km/h
<b>Longueur totale</b> Total length · Gesamtlänge	3,80 m

158 x 62 mm 2 x Decorations provided

## CITROËN 2CV FOURGONNETTE AK 250

**REF: 82701**  
Plus d'informations  
More about this product  
Mehr zu diesem Produkt



**REF: 58701**  
Starter Kit



2023

## CITROËN FOURGON HY

REF: 80768  
Plus d'informations  
More about this product  
Mehr zu diesem Produkt



REF: 56768  
Starter Kit



1964 HY 75 1964 HY 75 10

1949 HY 61 1949 HY 61 10

2015 JC 33 2015 JC 33 10

80768 - 070 CITROËN HY Heller



2015 2021

## CITROËN HY 1957/1964

REF: 80744  
Plus d'informations  
More about this product  
Mehr zu diesem Produkt



REF: 56744  
Starter Kit



Garage Acier „Service Citroën”



Biscuiterie de l'Abbaye



2015 2021



REF: 80768 **CITROËN FOURGON HY** Scale: 1/24

<b>Année de fabrication</b> Year of construction · Baujahr	1957/1964
<b>Quantité produite</b> Built quantity · Gebaute Menge	473.289
<b>Puissance</b> Power · Leistung	35/42 CV/PS
<b>Vitesse maximale</b> Max. Speed · Max. Geschwindigkeit	90 km/h
<b>Longueur totale</b> Total length · Gesamtlänge	4,26 m

177 x 83 mm 2 IN 1 (1957/1964) 138 pieces



REF: 80744 **CITROËN HY 1957/1964** Scale: 1/24

<b>Année de fabrication</b> Year of construction · Baujahr	1957 / 1964
<b>Quantité produite</b> Built quantity · Gebaute Menge	473.289
<b>Puissance</b> Power · Leistung	35/42 CV/PS
<b>Vitesse maximale</b> Max. Speed · Max. Geschwindigkeit	90 km/h
<b>Longueur totale</b> Total length · Gesamtlänge	4,26 m

177 x 83 mm 2 IN 1 (1957/1964) 2 x Decorations provided 138 pieces

Heller



PREVIEW

**CITROËN HY + GOODS TRAILER**

REF: 50331 Scale: 1/24

	CITROËN FOURGON HY	GOODS TRAILER
<b>Année de fabrication</b> Year of construction • Baujahr	1957 / 1964	1976
<b>Quantité produite</b> Built quantity • Gebaute Menge	473 289	/
<b>Puissance</b> Power • Leistung	35/42 CV/PS	/
<b>Vitesse maximale</b> Max. Speed • Max. Geschwindigkeit	90 km/h	80 km/h
<b>Longueur totale</b> Total length • Gesamtlänge	4,26 m	5,98 m

2 x 177 x 85 mm  
254 x 94 mm

2 IN 1 (1957 / 1964) 138 + 151 pieces

## CITROËN HY + GOODS TRAILER

**REF: 50331**  
Plus d'informations  
More about this product  
Mehr zu diesem Produkt



**REF: 52331**  
Starter Kit



**2015** **2021** **2023**

Heller



**RENAULT ESTAFETTE GENDARMERIE**

REF: 80742 Scale: 1/24

<b>Année de fabrication</b> Year of construction • Baujahr	1964 / 1973
<b>Quantité produite</b> Built quantity • Gebaute Menge	500.000 (total)
<b>Puissance</b> Power • Leistung	45 CV/PS
<b>Vitesse maximale</b> Max. Speed • Max. Geschwindigkeit	90 km/h
<b>Longueur totale</b> Total length • Gesamtlänge	4,1 m

160 x 74 mm

2 IN 1 (1964/1973) 167 pieces

## RENAULT ESTAFETTE GENDARMERIE

**REF: 80742**  
Plus d'informations  
More about this product  
Mehr zu diesem Produkt



**REF: 56742**  
Starter Kit





1

2

3

4

6

281  
0563

5

9

7

8

8

80742 - 170

ESTAFETTE Gendarmerie

1964



1973

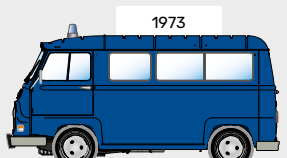

**2021**





REF: 80773 **SCANIA LB-141** Scale: 1/24

<b>Année de fabrication</b> Year of construction • Baujahr	1977
<b>Quantité produite</b> Built quantity • Gebaute Menge	20.000
<b>Puissance</b> Power • Leistung	375 CV/PS
<b>Vitesse maximale</b> Max. Speed • Max. Geschwindigkeit	110 km/h
<b>Longueur totale</b> Total length • Gesamtlänge	5,64 m

235 x 95 mm      4 x Decorations provided      210 pieces

**SCANIA LB-141**

REF: 80773  
Plus d'informations  
More about this product  
Mehr zu diesem Produkt



REF: 56773  
Starter Kit



Parts list includes: SCANIA 1, 2, 3, 4, 5, 6, 7, 9, 10, 11, 12, 13, 14, 15, 16, 17, 18, 19, 20, 21, 22, 23, 24, 25, 26, 80, 60, 141, 1004 RS 56, 2215 HP 13, GRH 178 N, MB = W1768, PANALPINA, DANZAS, KÜHNE & NAGEL, Scania LB 141-34, 1980, DANZAS, 1980, PANALPINA, 1980.

1980 2021

**FAREWELL, TRANSALL!**

The legendary tactical transport aircraft lives on at Heller in 1/72 scale with its special farewell paint scheme „Retro Brummel“.



**NEW**

**TRANSALL C-160 „RETRO BRUMMEL“**

REF: 80358

Scale: 1/72	57 Pieces
451 x 555 mm	

More about this product





## DELAHAYE TYPE 103 POMPIERS

REF: 80780  
Plus d'informations  
More about this product  
Mehr zu diesem Produkt



REF: 56780  
Starter Kit

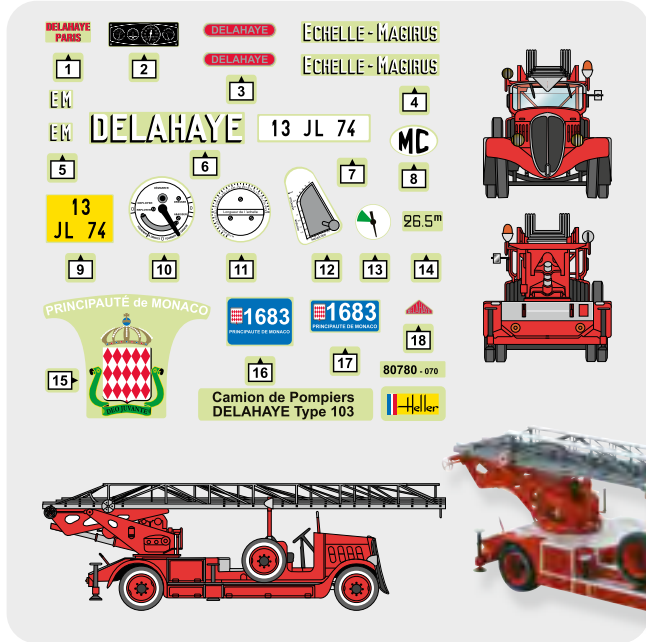

1980 2023



REF: 80780 **DELAHAYE TYPE 103 POMPIERS** Scale: 1/24

<b>Année de fabrication</b> Year of construction - Baujahr	1937 / 1939
<b>Quantité produite</b> Built quantity - Gebaute Menge	1
<b>Puissance</b> Power - Leistung	90 CV/PS
<b>Vitesse maximale</b> Max. Speed - Max. Geschwindigkeit	60 km/h
<b>Longueur totale</b> Total length - Gesamtlänge	8,35 m

350 x 95 mm    2 x Decorations provided    210 pieces

## AUTOBUS PARISEN TN6 C2

REF: 80789  
Plus d'informations  
More about this product  
Mehr zu diesem Produkt



REF: 56789  
Starter Kit

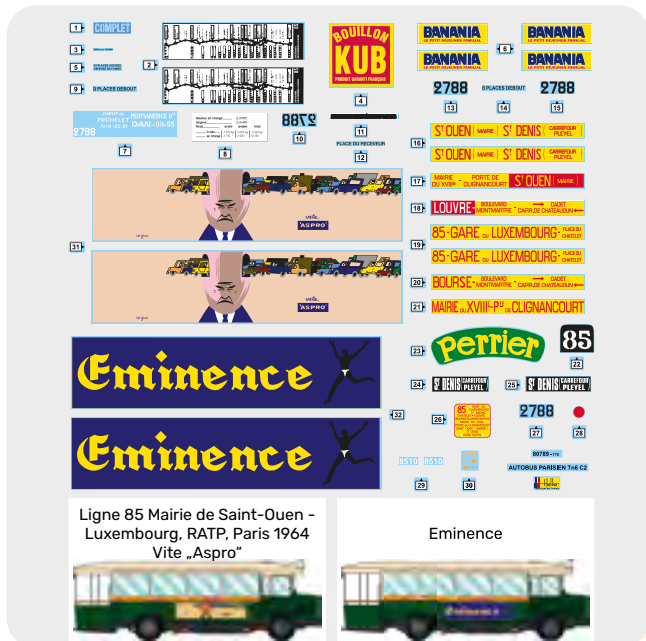

1982 2021

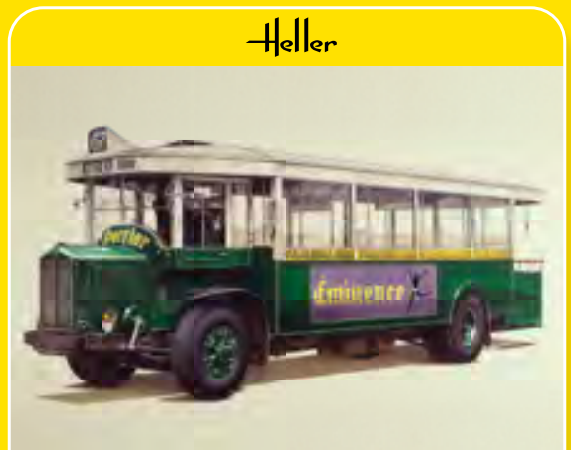

REF: 80789 **AUTOBUS PARISEN TN6 C2** Scale: 1/24

<b>Année de fabrication</b> Year of construction - Baujahr	1934
<b>Quantité produite</b> Built quantity - Gebaute Menge	160
<b>Puissance</b> Power - Leistung	Gasoline 67 CV/PS Diesel 94 CV/PS
<b>Vitesse maximale</b> Max. Speed - Max. Geschwindigkeit	Gasoline 45 km/h Diesel 55 km/h
<b>Longueur totale</b> Total length - Gesamtlänge	9,50 m

394 x 102 mm    2 x Decorations provided    198 pieces

Heller



REF: 81401

**FERGUSON  
PETIT GRIS**

Scale: 1/24

<b>Année de fabrication</b> Year of construction • Baujahr	1946 (UK) / 1952 (France)
<b>Quantité produite</b> Built quantity • Gebaute Menge	723.310
<b>Puissance</b> Power • Leistung	24/28 CV/PS
<b>Vitesse maximale</b> Max. Speed • Max. Geschwindigkeit	25 km/h
<b>Longueur totale</b> Total length • Gesamtlänge	2,90 m

110 x 70 mm      2 IN 1 (TE=20/FF=30)      128 pieces

**FERGUSON PETIT GRIS**

REF: 81401  
Plus d'informations  
More about this product  
Mehr zu diesem Produkt



REF: 57401  
Starter Kit



81401-070

**FERGUSON Petit Gris**

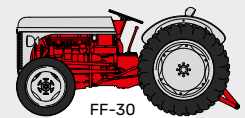
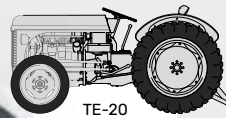

2016

Heller



REF: 50326

**FERGUSON PETIT GRIS  
TE-20 + FF-30  
+ DIORAMA**

Scale: 1/24

<b>Année de fabrication</b> Year of construction • Baujahr	1946 (UK) / 1952 (France)
<b>Quantité produite</b> Built quantity • Gebaute Menge	723.310
<b>Puissance</b> Power • Leistung	24 CV/PS (UK) / 28 CV/PS (France)
<b>Vitesse maximale</b> Max. Speed • Max. Geschwindigkeit	25 km/h
<b>Longueur totale</b> Total length • Gesamtlänge	2,90 m

2 x 110 x 70 mm      1 x 342 x 235 mm      2 x 128 pieces

**FERGUSON PETIT GRIS TE-20 + FF-30  
+ DIORAMA**

REF: 50326  
Plus d'informations  
More about this product  
Mehr zu diesem Produkt



REF: 52326  
Starter Kit



2x

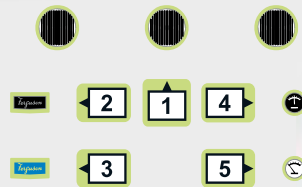

81401-070

**FERGUSON Petit Gris**



Diorama included  
without decoration.

UK: TE-20 „Petit Gris“

France: FF-30 „Ventre rouge“

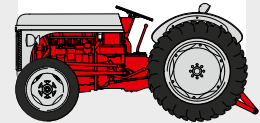
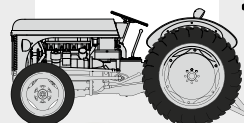

2016

## MASSEY FERGUSON 2680

REF: 81402  
Plus d'informations  
More about this product  
Mehr zu diesem Produkt



REF: 57402  
Starter Kit

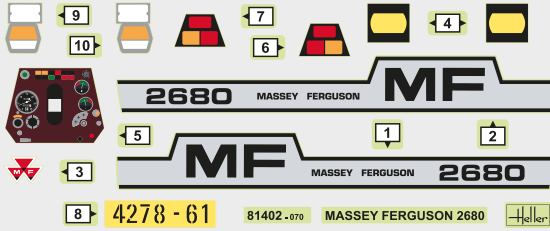

1983 2020

## LANDINI 16000 DT

REF: 81403  
Plus d'informations  
More about this product  
Mehr zu diesem Produkt



REF: 57403  
Starter Kit



1983 2020



REF: 81402

**MASSEY  
FERGUSON 2680**

Scale: 1/24

<b>Année de fabrication</b> Year of construction · Baujahr	1982
<b>Quantité produite</b> Built quantity · Gebaute Menge	2.952
<b>Puissance</b> Power · Leistung	125 CV/PS
<b>Vitesse maximale</b> Max. Speed · Max. Geschwindigkeit	25 km/h
<b>Longueur totale</b> Total length · Gesamtlänge	5,15 m

214 x 98 mm

45 pieces



REF: 81403

**LANDINI  
16000 DT**

Scale: 1/24

<b>Année de fabrication</b> Year of construction · Baujahr	1986
<b>Quantité produite</b> Built quantity · Gebaute Menge	100
<b>Puissance</b> Power · Leistung	147 CV/PS
<b>Vitesse maximale</b> Max. Speed · Max. Geschwindigkeit	25 km/h
<b>Longueur totale</b> Total length · Gesamtlänge	5,15 m

214,5 x 98,5 mm

45 pieces

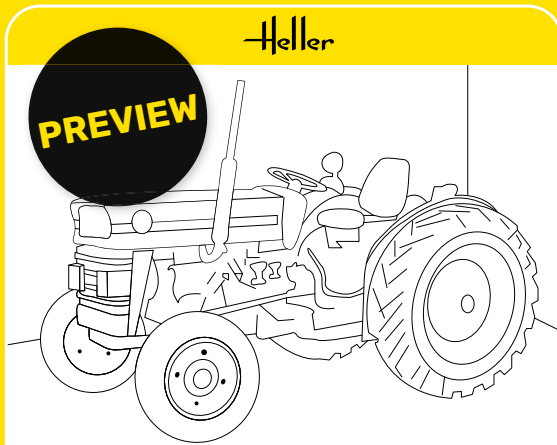

REF: 81404 **MASSEY FERGUSON 135** Scale: 1/24

<b>Année de fabrication</b> Year of construction • Baujahr	1957 / 1964
<b>Quantité produite</b> Built quantity • Gebaute Menge	ca. 350.000
<b>Puissance</b> Power • Leistung	45 CV / PS
<b>Vitesse maximale</b> Max. Speed • Max. Geschwindigkeit	20 km/h
<b>Longueur totale</b> Total length • Gesamtlänge	3,05 m

127 x 67 mm

**MASSEY FERGUSON 135**

REF: 81404  
Plus d'informations  
More about this product  
Mehr zu diesem Produkt



REF: 57404  
Starter Kit



2023



REF: 80774 **CAR TRANSPORTER TRAILER** Scale: 1/24

<b>Année de fabrication</b> Year of construction • Baujahr	1975 / 1987
<b>Quantité produite</b> Built quantity • Gebaute Menge	/
<b>Puissance</b> Power • Leistung	/
<b>Vitesse maximale</b> Max. Speed • Max. Geschwindigkeit	80 km/h
<b>Longueur totale</b> Total length • Gesamtlänge	5,98 m

254 x 94 mm 86 pieces

**CAR TRANSPORTER TRAILER**

REF: 80774  
Plus d'informations  
More about this product  
Mehr zu diesem Produkt



REF: 56774  
Starter Kit



2023

## GOODS TRAILER

REF: 80778  
Plus d'informations  
More about this product  
Mehr zu diesem Produkt



REF: 56778  
Starter Kit



NEW  
TOOL

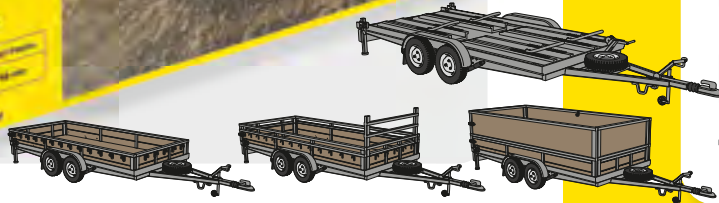

2023



REF: 80778

**GOODS TRAILER**

Scale: 1/24

<b>Année de fabrication</b> Year of construction - Baujahr	1975 / 1987
<b>Quantité produite</b> Built quantity - Gebaute Menge	/
<b>Puissance</b> Power - Leistung	/
<b>Vitesse maximale</b> Max. Speed - Max. Geschwindigkeit	80 km/h
<b>Longueur totale</b> Total length - Gesamtlänge	5,98 m
 254 x 94 mm	4 IN 1
	151 pieces

## FRENCH GENDARMERIE OFFICERS

REF: 82751  
Plus d'informations  
More about this product  
Mehr zu diesem Produkt



REF: 58751  
Starter Kit



NEW  
TOOL



2023



REF: 82751

**FRENCH GENDARMERIE OFFICERS**

Scale: 1/24

<b>Nation</b> Nation - Nation	France
 73 mm	3 pieces



REF: 82750

**RACING TEAM + ACCESSORIES**

Scale: 1/24

Nation  
Nation • Nation Europe



72 mm

35 pieces

**RACING TEAM + ACCESSORIES**

REF: 82750  
Plus d'informations  
More about this product  
Mehr zu diesem Produkt



REF: 58750  
Starter Kit



**NEW SET**



1984 2022



REF: 81704

**VOLVO F12-20  
TIMBER SEMI TRAILER**

Scale: 1/32

<b>Année de fabrication</b> Year of construction • Baujahr	1977
<b>Quantité produite</b> Built quantity • Gebaute Menge	200.000
<b>Puissance</b> Power • Leistung	385 CV/PS
<b>Vitesse maximale</b> Max. Speed • Max. Geschwindigkeit	110 km/h
<b>Longueur totale</b> Total length • Gesamtlänge	5,44 m

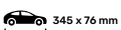

345 x 76 mm

146 pieces

**VOLVO F12-20 TIMBER SEMI TRAILER**

REF: 81704  
Plus d'informations  
More about this product  
Mehr zu diesem Produkt



REF: 57704  
Starter Kit

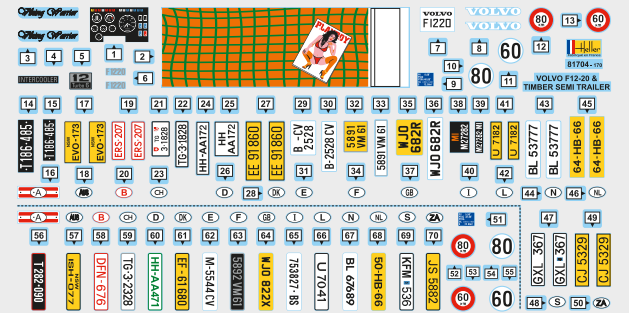

1985 2020

## VOLVO F12-20 GLOBETROTTER & CONTAINER SEMI TRAILER

REF: 81702  
Plus d'informations  
More about this product  
Mehr zu diesem Produkt



REF: 57702  
Starter Kit

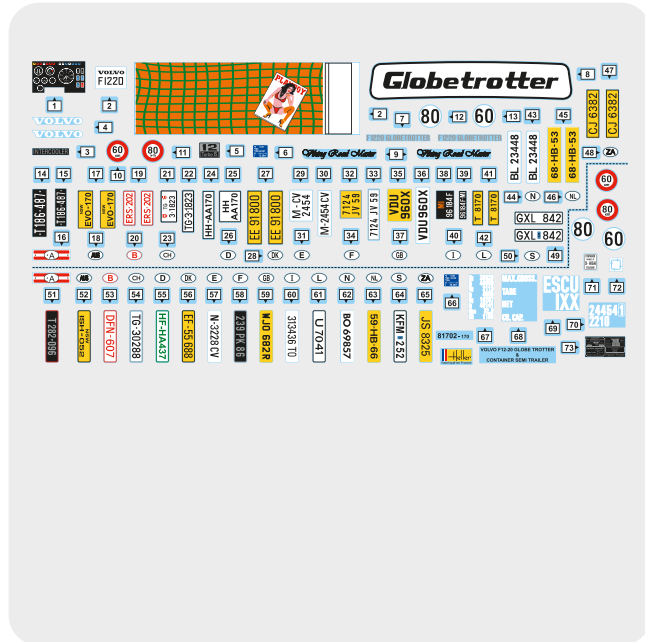

1985 2020

## VOLVO F12-20 GLOBETROTTER & TWIN-AXLE SEMI TRAILER

REF: 81703  
Plus d'informations  
More about this product  
Mehr zu diesem Produkt



REF: 57703  
Starter Kit



1985 2020



### VOLVO F12-20 GLOBETROTTER & CONTAINER SEMI TRAILER

REF: 81702

Scale: 1/32

<b>Année de fabrication</b> Year of construction - Baujahr	1977
<b>Quantité produite</b> Built quantity - Gebaute Menge	200.000
<b>Puissance</b> Power - Leistung	385 CV/PS
<b>Vitesse maximale</b> Max. Speed - Max. Geschwindigkeit	110 km/h
<b>Longueur totale</b> Total length - Gesamtlänge	5,44 m

345 x 76 mm

145 pieces



### VOLVO F12-20 GLOBETROTTER & TWIN-AXLE SEMI TRAILER

REF: 81703

Scale: 1/32

<b>Année de fabrication</b> Year of construction - Baujahr	1977
<b>Quantité produite</b> Built quantity - Gebaute Menge	200.000
<b>Puissance</b> Power - Leistung	385 CV/PS
<b>Vitesse maximale</b> Max. Speed - Max. Geschwindigkeit	110 km/h
<b>Longueur totale</b> Total length - Gesamtlänge	5,44 m

345 x 76 mm

142 pieces



REF: 80146 **ALPINE A310 V6** Scale: 1/43

<b>Année de fabrication</b> Year of construction • Baujahr	1971
<b>Quantité produite</b> Built quantity • Gebaute Menge	9.166
<b>Puissance</b> Power • Leistung	148 CV/PS
<b>Vitesse maximale</b> Max. Speed • Max. Geschwindigkeit	225 km/h
<b>Longueur totale</b> Total length • Gesamtlänge	4,18 m

97 x 38 mm 50 pieces



REF: 80159 **CITROËN 11 CV** Scale: 1/43

<b>Année de fabrication</b> Year of construction • Baujahr	1934
<b>Quantité produite</b> Built quantity • Gebaute Menge	759.111 (total)
<b>Puissance</b> Power • Leistung	56 CV/PS
<b>Vitesse maximale</b> Max. Speed • Max. Geschwindigkeit	120 km/h
<b>Longueur totale</b> Total length • Gesamtlänge	4,45 m

101 x 38 mm 29 pieces



REF: 80175 **CITROËN 2CV** Scale: 1/43

<b>Année de fabrication</b> Year of construction • Baujahr	1948
<b>Quantité produite</b> Built quantity • Gebaute Menge	125.573 (A model)
<b>Puissance</b> Power • Leistung	9 CV/PS
<b>Vitesse maximale</b> Max. Speed • Max. Geschwindigkeit	60 km/h
<b>Longueur totale</b> Total length • Gesamtlänge	3,73 m

88 x 34 mm 21 pieces

REF: 80146



REF: 56146

Starter Kit



REF: 80159



REF: 56159

Starter Kit



REF: 80175



REF: 56175

Starter Kit



REF: 80162 **CITROËN DS 19** Scale: 1/43

<b>Année de fabrication</b> Year of construction • Baujahr	1960
<b>Quantité produite</b> Built quantity • Gebaute Menge	1.455.746
<b>Puissance</b> Power • Leistung	75 CV/PS
<b>Vitesse maximale</b> Max. Speed • Max. Geschwindigkeit	150 km/h
<b>Longueur totale</b> Total length • Gesamtlänge	4,83 m

112 x 43 mm 26 pieces



REF: 80149 **928** Scale: 1/43

<b>Année de fabrication</b> Year of construction • Baujahr	1979
<b>Quantité produite</b> Built quantity • Gebaute Menge	62.000
<b>Puissance</b> Power • Leistung	240-350 CV/PS
<b>Vitesse maximale</b> Max. Speed • Max. Geschwindigkeit	250 km/h
<b>Longueur totale</b> Total length • Gesamtlänge	4,44 m

103 x 43 mm 45 pieces



REF: 80176 **BERLINE K70** Scale: 1/43

<b>Année de fabrication</b> Year of construction • Baujahr	1969
<b>Quantité produite</b> Built quantity • Gebaute Menge	211.127
<b>Puissance</b> Power • Leistung	90 CV/PS
<b>Vitesse maximale</b> Max. Speed • Max. Geschwindigkeit	158 km/h
<b>Longueur totale</b> Total length • Gesamtlänge	4,47 m

102 x 39 mm 37 pieces

REF: 80162



REF: 56162

Starter Kit



REF: 80149



REF: 56149

Starter Kit



REF: 80176



REF: 56176

Starter Kit





**Heller**



**REF: 80153 AUSTIN MINI** Scale: 1/43

<b>Année de fabrication</b> Year of construction • Baujahr	1960
<b>Quantité produite</b> Built quantity • Gebaute Menge	5.387.862
<b>Puissance</b> Power • Leistung	35 CV/PS
<b>Vitesse maximale</b> Max. Speed • Max. Geschwindigkeit	115 km/h
<b>Longueur totale</b> Total length • Gesamtlänge	3,05 m

 71 x 34 mm 52 pieces

**Heller**



**REF: 80160 PEUGEOT 203** Scale: 1/43

<b>Année de fabrication</b> Year of construction • Baujahr	1950
<b>Quantité produite</b> Built quantity • Gebaute Menge	699.863
<b>Puissance</b> Power • Leistung	45 CV/PS
<b>Vitesse maximale</b> Max. Speed • Max. Geschwindigkeit	110 km/h
<b>Longueur totale</b> Total length • Gesamtlänge	4,53 m

 102 x 38 mm 36 pieces

**Heller**



**REF: 80161 PEUGEOT 403** Scale: 1/43



<b>Année de fabrication</b> Year of construction • Baujahr	1955
<b>Quantité produite</b> Built quantity • Gebaute Menge	1.214.126
<b>Puissance</b> Power • Leistung	58 CV/PS
<b>Vitesse maximale</b> Max. Speed • Max. Geschwindigkeit	135 km/h
<b>Longueur totale</b> Total length • Gesamtlänge	4,47 m

 104 x 39 mm 36 pieces

REF: 80153  REF: 56153 Starter Kit 

REF: 80160  REF: 56160 Starter Kit 

REF: 80161  REF: 56161 Starter Kit 

**Heller**



**REF: 80174 RENAULT 4 CV** Scale: 1/43

<b>Année de fabrication</b> Year of construction • Baujahr	1947
<b>Quantité produite</b> Built quantity • Gebaute Menge	1.105.547 (total)
<b>Puissance</b> Power • Leistung	17 CV/PS
<b>Vitesse maximale</b> Max. Speed • Max. Geschwindigkeit	95 km/h
<b>Longueur totale</b> Total length • Gesamtlänge	3,60 m

 85 x 33 mm 40 pieces

**Heller**



**REF: 80150 RENAULT R5 TURBO** Scale: 1/43

<b>Année de fabrication</b> Year of construction • Baujahr	1980
<b>Quantité produite</b> Built quantity • Gebaute Menge	4.857
<b>Puissance</b> Power • Leistung	160 CV/PS
<b>Vitesse maximale</b> Max. Speed • Max. Geschwindigkeit	204 km/h
<b>Longueur totale</b> Total length • Gesamtlänge	3,66 m

 84 x 41 mm 30 pieces



**Heller**



**REF: 95201 ACRYLIC SHOWCASE**



97 mm x 135 mm x 260 mm (depth 80 mm)  300 g

REF: 80174  REF: 56174 Starter Kit 

REF: 80150  REF: 56150 Starter Kit 

REF: 95201 

Plus d'informations  
More about this product  
Mehr zu diesem Produkt



REF: 80113 **PEUGEOT 206 WRC'03** Scale: 1/43

<b>Année de fabrication</b> Year of construction • Baujahr	2003
<b>Quantité produite</b> Built quantity • Gebaute Menge	/
<b>Puissance</b> Power • Leistung	300 CV/PS
<b>Vitesse maximale</b> Max. Speed • Max. Geschwindigkeit	240 km/h
<b>Longueur totale</b> Total length • Gesamtlänge	4 m

94 x 48 mm

37 pieces

**PEUGEOT 206 WRC'03**

REF: 80113  
Plus d'informations  
More about this product  
Mehr zu diesem Produkt



REF: 56113  
Starter Kit

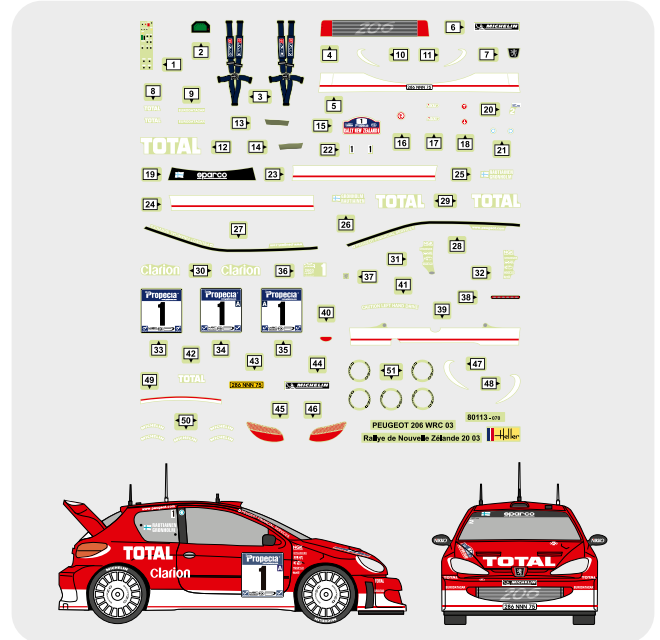

1999 2022



REF: 80196 **FOCUS WRC'01** Scale: 1/43

<b>Année de fabrication</b> Year of construction • Baujahr	2001
<b>Quantité produite</b> Built quantity • Gebaute Menge	/
<b>Puissance</b> Power • Leistung	300 CV/PS
<b>Vitesse maximale</b> Max. Speed • Max. Geschwindigkeit	240 km/h
<b>Longueur totale</b> Total length • Gesamtlänge	4,15 m

97 x 42 mm

28 pieces

**FOCUS WRC'01**

REF: 80196  
Plus d'informations  
More about this product  
Mehr zu diesem Produkt



REF: 56196  
Starter Kit



2001 2022

## SUBARU IMPREZA WRC'02

REF: 80199  
Plus d'informations  
More about this product  
Mehr zu diesem Produkt



REF: 56199  
Starter Kit

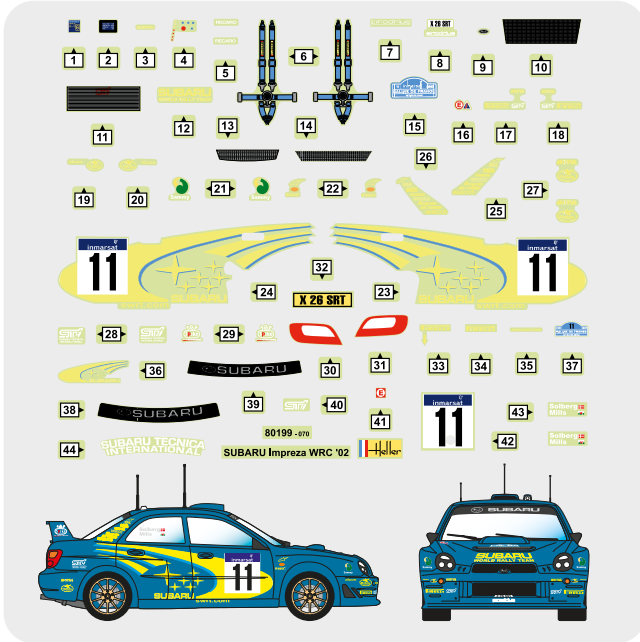

2003 2021

## PEUGEOT 205 TURBO RALLYE

REF: 80189  
Plus d'informations  
More about this product  
Mehr zu diesem Produkt



REF: 56189  
Starter Kit



1987 2021



REF: 80199

### SUBARU IMPREZA WRC'02

Scale: 1/43

<b>Année de fabrication</b> Year of construction - Baujahr	2001
<b>Quantité produite</b> Built quantity - Gebaute Menge	/
<b>Puissance</b> Power - Leistung	350 CV/PS
<b>Vitesse maximale</b> Max. Speed - Max. Geschwindigkeit	228 km/h
<b>Longueur totale</b> Total length - Gesamtlänge	4,34 m

102 x 43 mm

28 pieces



REF: 80189

### PEUGEOT 205 TURBO RALLYE

Scale: 1/43

<b>Année de fabrication</b> Year of construction - Baujahr	1987
<b>Quantité produite</b> Built quantity - Gebaute Menge	3
<b>Puissance</b> Power - Leistung	360 CV / PS
<b>Vitesse maximale</b> Max. Speed - Max. Geschwindigkeit	240 km/h
<b>Longueur totale</b> Total length - Gesamtlänge	3,82 m

99 x 41 mm

2 x Decorations provided

29 pieces





Heller

**VÉHICULES  
MILITAIRES**

MILITARY VEHICLES  
MILITÄRISCHE FAHRZEUGE

# GEPARD

**Français** Le char de combat antiaérien Gepard (FlakPz Gepard) est un char antiaérien autonome de fabrication allemande, très mobile et capable de combattre par tous les temps, qui a été développé et produit dès les années 1970. Pendant longtemps, il constitua une pierre angulaire de la défense antiaérienne de l'armée de la Bundeswehr. Le Gepard fut développé pour offrir aux troupes mobiles de chars et de grenadiers de chars de la Bundeswehr une protection contre les avions volant à basse altitude et les hélicoptères de combat dans le cadre du combat interarmes tactique. Le choix de l'armement a également pris en compte la lutte contre les hélicoptères de combat fortement blindés comme le Mil Mi-24 « Hind », dont le blindage offrait une protection efficace contre les projectiles jusqu'au calibre 23 mm. Lors du combat contre des cibles au sol, comme des chars ou des véhicules roulants, l'acquisition et le suivi se faisaient visuellement via l'un des périscopes du commandant ou du canonier de direction.

**English** The Gepard anti-aircraft gun tank (FlakPz Gepard) is a German-built, autonomous, highly mobile, all-weather combat-capable anti-aircraft tank that was developed and produced as early as the 1970s. For a long time, it formed a cornerstone of the Bundeswehr's air defence. The Gepard was developed to provide the mobile tank and armoured infantry troops of the Bundeswehr with protection against low-flying aircraft and combat helicopters in the tactical context of the battle of the linked weapons. The choice of armament also took into account the combat of heavily armoured attack helicopters such as the Mil Mi-24 „Hind“, whose armour effectively provided protection against projectiles up to 23mm calibre. When engaging ground targets such as tanks or wheeled vehicles, detection and tracking was done visually via one of the commander's or gunner's periscopes.

**Deutsch** Der Flugabwehrkanonenpanzer Gepard (FlakPz Gepard) ist ein aus deutscher Produktion stammender autonomer, hochmobiler, allwetterkampffähiger FlaK-Panzer, der bereits in den 1970er-Jahren entwickelt und produziert wurde. Er bildete für lange Zeit einen Eckpfeiler der Flugabwehr des Heeres der Bundeswehr. Der Gepard wurde entwickelt, um den beweglichen Panzer- und Panzergrenadiertruppen der Bundeswehr Schutz vor tieffliegenden Flugzeugen und Kampfhubschraubern im taktischen Rahmen des Gefechts der verbundenen Waffen zu geben. Die Auswahl der Bewaffnung berücksichtigte auch die Bekämpfung von stark gepanzerten Kampfhubschraubern wie dem Mil Mi-24 „Hind“, dessen Panzerung effektiv Schutz vor Geschossen bis zum Kaliber 23mm bot. Bei der Bekämpfung von Bodenzielen, wie Panzern oder Radfahrzeugen, erfolgte die Erfassung und Verfolgung visuell über eines der Periskope von Kommandant oder Richtkanonier.



REF: 81127

**GEPARD**

Scale: 1/35

<b>Année de fabrication</b> Year of construction • Baujahr	1976
<b>Quantité produite</b> Built quantity • Gebaute Menge	420
<b>Moteur</b> Engine • Motor	10-Cylinder, MTU MB 838 CaM 500
<b>Vitesse maximale</b> Max. Speed • Max. Geschwindigkeit	65 km/h
<b>Poids</b> Weight • Gewicht	47,3 t



220 x 96 mm

5 x Decorations provided

320 pieces

1976 2022

REF: 81127

Plus d'informations  
More about this product  
Mehr zu diesem Produkt



REF: 57127  
Starter Kit



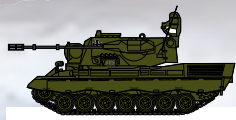

3/6. 314. Pz.Flak.Lehr.Batl. 6,  
Lütjenburg, 1979



612, Pz.Flak.Btl. 132,  
Hohenmölsen, 1980



Pz.Flak.Btl. ,  
unkown unit, 1981



Romania, 41341, 2004



Ukraine, 596, 2022 (fictional)

Heller



REF: 30320

**StuG III**

Scale: 1/16

<b>Année de fabrication</b> Year of construction • Baujahr	1942
<b>Quantité produite</b> Built quantity • Gebaute Menge	ca. 7800
<b>Moteur</b> Engine • Motor	Maybach HL 120
<b>Vitesse maximale</b> Max. Speed • Max. Geschwindigkeit	40 km/h
<b>Poids</b> Weight • Gewicht	23.9t

 420 x 204 mm    6 x Decorations provided    1300+ pieces

**StuG III**

**REF: 30320**  
Plus d'informations  
More about this product  
Mehr zu diesem Produkt



Pz.Abt.215, 15.Pz.Gren.Div., Sicily 1943

Italy 1944

Easternfront winter 1944/45

Normandy 1944

Berlin 1945

Russia summer 1944



Heller



REF: 30321

**Pz.Kpfw. III**

Scale: 1/16

<b>Année de fabrication</b> Year of construction • Baujahr	1939
<b>Quantité produite</b> Built quantity • Gebaute Menge	ca. 5700
<b>Moteur</b> Engine • Motor	Maybach HL 120
<b>Vitesse maximale</b> Max. Speed • Max. Geschwindigkeit	40 km/h
<b>Poids</b> Weight • Gewicht	21.6t

 420 x 205 mm  
343 x 188 mm    4 x Decorations provided  
4 IN 1    1500+ pieces

**Pz.Kpfw. III**

**REF: 30321**  
Plus d'informations  
More about this product  
Mehr zu diesem Produkt



Ausf. M

Ausf. M  
Pz.Rgt.3,2.PZ.Div., Kursk 1943

Ausf. J  
2.Pz.Div., Russia 1941

Ausf. L





## US 1/4 TON TRUCK 'N TRAILER

**REF: 81105**  
Plus d'informations  
More about this product  
Mehr zu diesem Produkt



**REF: 57105**  
Starter Kit



**USA: Unité non identifiée, Normandie, France, juin 1944**

**GB: Royal Ulster Rifles, 6th Air Landing Brigade, 6th AD, Normandie, France, 7 juin 1944**

**USA: Unité non identifiée, Normandie, France, juin 1944**

1977 2021

## GMC CCKW 353

**REF: 81121**  
Plus d'informations  
More about this product  
Mehr zu diesem Produkt



**REF: 57121**  
Starter Kit



**USA : GMC CCKW 353, 6 Juin 1944**

**France : GMC CCKW 353 2ème DB, Août 1944**

1978 2020



REF: 81105

### US 1/4 TON TRUCK 'N TRAILER

Scale: 1/35

<b>Année de fabrication</b> Year of construction - Baujahr	1941
<b>Quantité produite</b> Built quantity - Gebaute Menge	370.000
<b>Puissance</b> Power - Leistung	61 CV/PS
<b>Vitesse maximale</b> Max. Speed - Max. Geschwindigkeit	100 km/h
<b>Longueur totale</b> Total length - Gesamtlänge	3,32 m

168 x 48 mm      2 x Decorations provided      107 pieces



REF: 81121

### GMC CCKW 353

Scale: 1/35

<b>Année de fabrication</b> Year of construction - Baujahr	1941
<b>Quantité produite</b> Built quantity - Gebaute Menge	800.000
<b>Puissance</b> Power - Leistung	104 CV/PS
<b>Vitesse maximale</b> Max. Speed - Max. Geschwindigkeit	71 km/h
<b>Longueur totale</b> Total length - Gesamtlänge	6,93 m

196 x 64 mm      2 x Decorations provided      226 pieces

Heller



REF: 81132

**HOTCHKISS H 35**

Scale: 1/35

<b>Année de fabrication</b> Year of construction · Baujahr	1936
<b>Quantité produite</b> Built quantity · Gebaute Menge	400
<b>Moteur</b> Engine · Motor	Hotchkiss 6 cylinders
<b>Canon</b> Cannon · Kanone	Canon SA18 37 mm / 7,5 mm machine gun
<b>Poids</b> Weight · Gewicht	11.370 kg

120 x 55 mm      2 x Decorations provided      137 pieces

**HOTCHKISS H 35**

REF: 81132  
Plus d'informations  
More about this product  
Mehr zu diesem Produkt



REF: 57132  
Starter Kit



18ème Dragons, 3ème peloton, 4ème escadron, 1ère DLM, 1937



4ème Cuirassiers, 3ème peloton, 2ème escadron, 1ère DLM, 1940

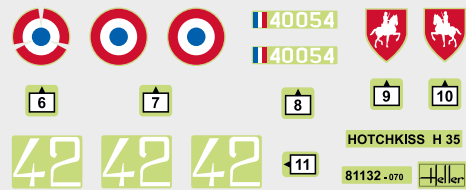

4ème Cuirassiers, 3ème peloton,  
2ème escadron, 1ère DLM, 1940



18ème Dragons, 3ème peloton,  
4ème escadron, 1ère DLM, 1937

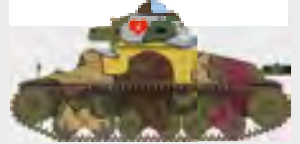

1978 2020

Heller

PREVIEW

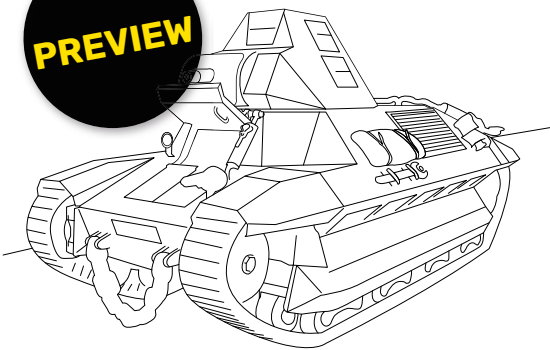

REF: 30322

**FCM36**

Scale: 1/35

<b>Année de fabrication</b> Year of construction · Baujahr	1939
<b>Quantité produite</b> Built quantity · Gebaute Menge	100
<b>Moteur</b> Engine · Motor	Berliet-Ricardo Diesel
<b>Canon</b> Cannon · Kanone	37-mm SA18
<b>Poids</b> Weight · Gewicht	12 t

126 x 63 mm      3 x Decorations provided      158 pieces

**FCM36**

REF: 30322  
Plus d'informations  
More about this product  
Mehr zu diesem Produkt



REF: 35322  
Starter Kit



## FRENCH TANK CREW

REF: 30323

Plus d'informations  
More about this product  
Mehr zu diesem Produkt



REF: 35323

Starter Kit



REF: 30323

**FRENCH TANK CREW**

Scale: 1/35

**Nation**

Nation • Nation

France

5x 55 mm

34 pieces

## AHN2 FRENCH TRUCK

REF: 30324

Plus d'informations  
More about this product  
Mehr zu diesem Produkt



REF: 35324

Starter Kit



REF: 30324

**AHN2 FRENCH TRUCK**

Scale: 1/35

**Année de fabrication**

Year of construction • Baujahr

1945

**Quantité produite**

Built quantity • Gebaute Menge

8400

**Moteur**

Engine • Motor

6 Cylinder Otto Engine

**Vitesse maximale**

Max. Speed • Max. Geschwindigkeit

59 km/h

**Poids**

Weight • Gewicht

2.2 t

181 x 65 mm

3 x Decorations provided

180 pieces

Heller

PREVIEW

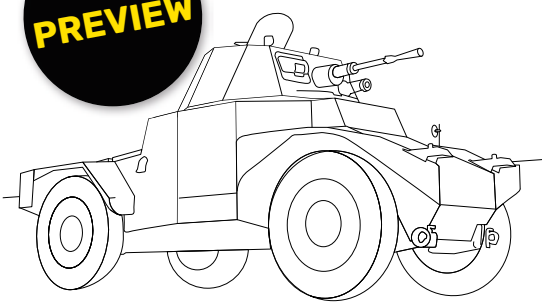

REF: 30325 **PANHARD 178** Scale: 1/35

<b>Année de fabrication</b> Year of construction · Baujahr	1938
<b>Quantité produite</b> Built quantity · Gebaute Menge	218
<b>Moteur</b> Engine · Motor	Panhard SK
<b>Canon</b> Cannon · Kanone	25-mm SA-35
<b>Poids</b> Weight · Gewicht	8,2 t

 145 x 58 mm      2 x Decorations provided      147 pieces

## PANHARD 178

REF: 30325  
Plus d'informations  
More about this product  
Mehr zu diesem Produkt



REF: 35325  
Starter Kit



Heller

PREVIEW

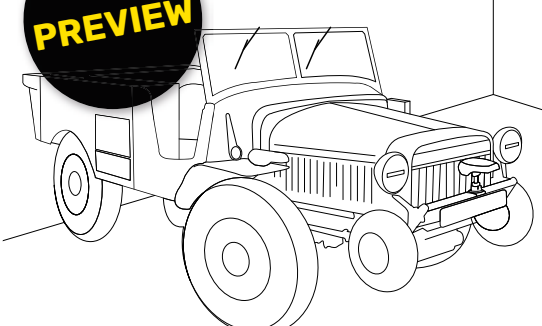

REF: 30326 **LAFFLY V 15 T + CANON** Scale: 1/35

<b>Année de fabrication</b> Year of construction · Baujahr	1939
<b>Quantité produite</b> Built quantity · Gebaute Menge	1386
<b>Moteur</b> Engine · Motor	2,3 L Hotchkiss
<b>Vitesse maximale</b> Max. Speed · Max. Geschwindigkeit	85 km/h
<b>Poids</b> Weight · Gewicht	1,8 t

 128 x 55 mm      2 x Decorations provided      211 pieces

## LAFFLY V 15 T + CANON

REF: 30326  
Plus d'informations  
More about this product  
Mehr zu diesem Produkt



REF: 35326  
Starter Kit



## LEOPARD 1A4

REF: 81126

Plus d'informations  
More about this product  
Mehr zu diesem Produkt



REF: 57126

Starter Kit



3/294, 421, PzBtl. 294,  
Stetten, 1979

Greece, 81132, 1983

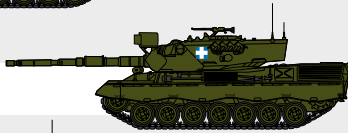

3/303, 335, PzBtl. 303,  
Heidenheim, 1980

Ukraine, 569, 2022 (fictional)



Canada, unknown unit,  
1978

1976 2022

## LECLERC T5/T6

REF: 81142

Plus d'informations  
More about this product  
Mehr zu diesem Produkt



REF: 57142

Starter Kit



Pièces photodécoupées  
Photoetched parts  
Fotoätzteile

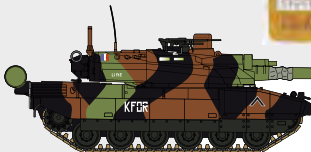
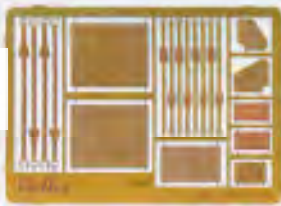

France: T5,  
6/12RC-501/503ème RCC,  
Srbica, Kosovo, Juin 2000

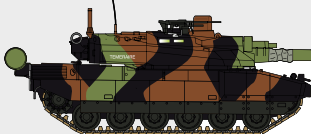

France: T5,  
501/503ème RC,  
Mourmelon 2002

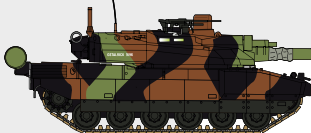

France: T6,  
11ème Cuir,  
Carpiagne 2003

1994 2021



REF: 81126

LEOPARD 1A4

Scale: 1/35

**Année de fabrication**

Year of construction - Baujahr

1976

**Quantité produite**

Built quantity - Gebaute Menge

250

**Moteur**

Engine - Motor

10-Cylinder, MTU MB  
838 CaM 500

**Vitesse maximale**

Max. Speed - Max. Geschwindigkeit

65 km/h

**Poids**

Weight - Gewicht

42,4 t



273 x 97 mm

5 x Decorations provided

317 pieces



REF: 81142

LECLERC T5/T6

Scale: 1/35

**Année de fabrication**

Year of construction - Baujahr

1993

**Quantité produite**

Built quantity - Gebaute Menge

310

**Moteur**

Engine - Motor

16470 cm³, Hyperbar-  
Diesel DU V-8X

**Canon**

Cannon - Kanone

120 mm

**Poids**

Weight - Gewicht

54,6 t



303 x 102 mm

3 x Decorations provided  
2 IN 1 (T5/T6)

259 pieces

Heller



REF: 81147

**VBCI**

Scale: 1/35

<b>Année de fabrication</b> Year of construction · Baujahr	2000
<b>Quantité produite</b> Built quantity · Gebaute Menge	>630
<b>Moteur</b> Engine · Motor	6-Cylinder Turbo Diesel Renault D12D
<b>Canon</b> Cannon · Kanone	1 x 25-mm-M811
<b>Poids</b> Weight · Gewicht	29 t

223 x 85 mm      3 x Decorations provided      261 pieces

**VBCI**

REF: 81147  
Plus d'informations  
More about this product  
Mehr zu diesem Produkt



REF: 57147  
Starter Kit



1	6094 0031		
4	6094 0058	6	3
8	6094 0034		
2	6094 0031	33	7
5	6094 0058	9	6094 0034

81147-170  
VBCI Heller

6094 0034, 92ème RI, Afghanistan, Hiver 2011  
6094 0031, 35ème RI, Afghanistan, Août 2010  
6094 0058, 92ème RI, Afghanistan, 2012



2012 2021

**VAB 4X4 UKRAINE**

REF: 81130  
Plus d'informations  
More about this product  
Mehr zu diesem Produkt



REF: 57130  
Starter Kit



**NEW PARTS & DECAL**



Heller



REF: 81130

**VAB 4X4 UKRAINE**

Scale: 1/35

<b>Année de fabrication</b> Year of construction · Baujahr	1991
<b>Quantité produite</b> Built quantity · Gebaute Menge	5.000
<b>Moteur</b> Engine · Motor	Renault MIDS 062045 Diesel
<b>Canon</b> Cannon · Kanone	1 x 7,62-mm-Machine gun AA-52
<b>Poids</b> Weight · Gewicht	13 t

171x72 mm      265 pieces

1999 2023

## SOMUA S 35

**REF: 79875**  
Plus d'informations  
More about this product  
Mehr zu diesem Produkt



**REF: 56875**  
Starter Kit

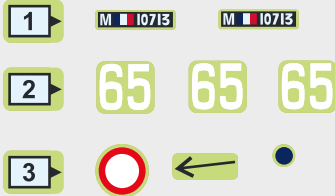

79875 - 070  
SOMUA S35



N°.65, M-10713, du 4ème Escadron du 2ème Cuirassiers, 3ème DLM, Belgique 1940

1979 2020

## M4 SHERMAN D-DAY

**REF: 79892**  
Plus d'informations  
More about this product  
Mehr zu diesem Produkt



**REF: 56892**  
Starter Kit

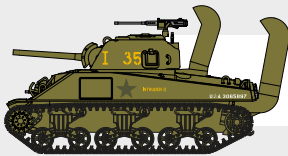

2nd Armored Division,  
67th Armored Regiment

2nd Armored Division,  
66th Armored Regiment



4th Armored Division,  
8th Tank Battalion



2013 2020



REF: 79875

**SOMUA S 35**

Scale: 1/72

<b>Année de fabrication</b> Year of construction · Baujahr	1937
<b>Quantité produite</b> Built quantity · Gebaute Menge	430
<b>Moteur</b> Engine · Motor	SOMUA V8
<b>Canon</b> Cannon · Kanone	Cannon SA 35 47 mm / 7,5 mm machine gun
<b>Poids</b> Weight · Gewicht	19,5 t

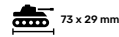

40 pieces



REF: 79892

**M4 SHERMAN D-DAY**

Scale: 1/72

<b>Année de fabrication</b> Year of construction · Baujahr	1942
<b>Quantité produite</b> Built quantity · Gebaute Menge	6.748
<b>Moteur</b> Engine · Motor	Continental R975 C1
<b>Canon</b> Cannon · Kanone	1 x 75 mm
<b>Poids</b> Weight · Gewicht	30.300 kg

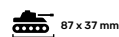

3 x Decorations provided

151 pieces



REF: 79894 **M42 SHERMAN DIVISION LECLERC** Scale: 1/72

<b>Année de fabrication</b> Year of construction · Baujahr	1943
<b>Quantité produite</b> Built quantity · Gebaute Menge	8.053
<b>Moteur</b> Engine · Motor	General Motors 6-71
<b>Canon</b> Cannon · Kanone	1 x 75 mm
<b>Poids</b> Weight · Gewicht	31.800 kg
80 x 37 mm	3 x Decorations provided
	159 pieces



**M4A2 SHERMAN DIVISION LECLERC**

REF: 79894  
Plus d'informations  
More about this product  
Mehr zu diesem Produkt



REF: 56894  
Starter Kit

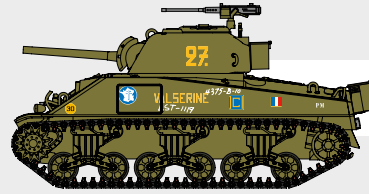

N° 27, „VALSERINE”,  
2ème DB, 12ème RCA



N° 24, „CHAMPAUBERT”,  
2ème DB, 501ème  
RCC



N° 40, „BRIVES LA  
GAILLARDE”, 2ème  
DB, 12ème CUIR

2013 2021



REF: 79995 **LCVP LANDING CRAFT VEHICLE & PERSONNEL** Scale: 1/72

<b>Année de fabrication</b> Year of construction · Baujahr	1942
<b>Quantité produite</b> Built quantity · Gebaute Menge	20.000
<b>Moteur</b> Engine · Motor	Gray Marine diesel
<b>Canon</b> Cannon · Kanone	2 x .30 Cal
<b>Poids</b> Weight · Gewicht	12.4 t / 8,5 t
150 x 46 mm	2 x Decorations provided
	88 pieces

**LCVP LANDING CRAFT VEHICLE & PERSONNEL**

REF: 79995  
Plus d'informations  
More about this product  
Mehr zu diesem Produkt



REF: 56995  
Starter Kit

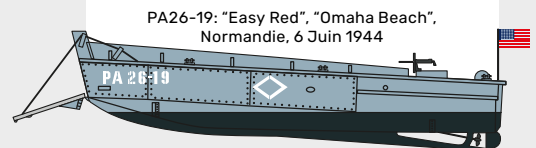
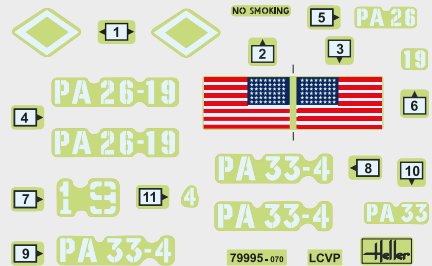

PA26-19: "Easy Red", "Omaha Beach",  
Normandie, 6 Juin 1944

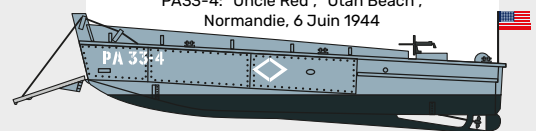

PA33-4: "Uncle Red", "Utah Beach",  
Normandie, 6 Juin 1944

2004 2021



## US 1/4 TON TRUCK & TRAILER

REF: 79997  
Plus d'informations  
More about this product  
Mehr zu diesem Produkt



REF: 56997  
Starter Kit

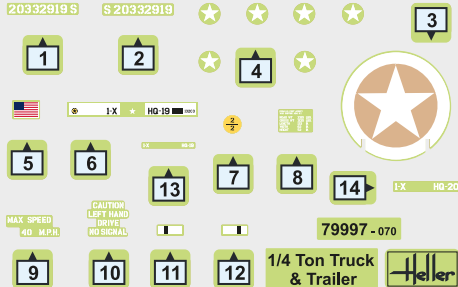

USA : Willys MB Jeep & trailer,  
15° US Infantry Division, Normandie, 6 Juin 1944

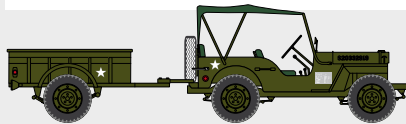

2004 2021

## GMC CCKW 353

REF: 79996  
Plus d'informations  
More about this product  
Mehr zu diesem Produkt



REF: 56996  
Starter Kit

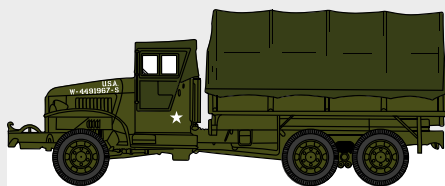
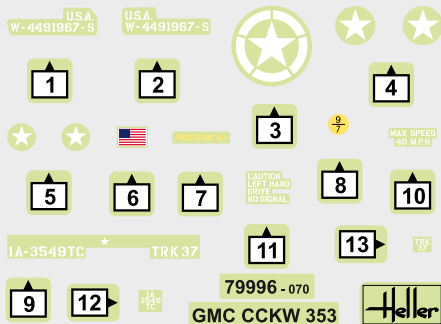

G.M.C. CCKW 353 : Us Army : 1st Army,  
3549th Transportation Corps,  
37th Truck Company, „Red Ball Express“, Août 1944

2004 2021



REF: 79997

### US 1/4 TON TRUCK & TRAILER

Scale: 1/72

<b>Année de fabrication</b> Year of construction - Baujahr	1941
<b>Quantité produite</b> Built quantity - Gebaute Menge	640.000
<b>Puissance</b> Power - Leistung	60 CV/PS
<b>Vitesse maximale</b> Max. Speed - Max. Geschwindigkeit	105 km
<b>Longueur totale</b> Total length - Gesamtlänge	3,36 m

85 x 27 mm

55 pieces



REF: 79996

### GMC CCKW 353

Scale: 1/72

<b>Année de fabrication</b> Year of construction - Baujahr	1941
<b>Quantité produite</b> Built quantity - Gebaute Menge	800.000
<b>Puissance</b> Power - Leistung	104 CV/PS
<b>Vitesse maximale</b> Max. Speed - Max. Geschwindigkeit	71 km
<b>Longueur totale</b> Total length - Gesamtlänge	6,93 m

96 x 33 mm

66 pieces



REF: 79899

**AMX 30/105**

Scale: 1/72

<b>Année de fabrication</b> Year of construction - Baujahr	1963
<b>Quantité produite</b> Built quantity - Gebaute Menge	2.471
<b>Moteur</b> Engine - Motor	Hispano Suiza HS 110
<b>Canon</b> Cannon - Kanone	1 x 105 mm
<b>Poids</b> Weight - Gewicht	32.500 kg

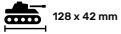

74 pieces

**AMX 30/105**

REF: 79899  
Plus d'informations  
More about this product  
Mehr zu diesem Produkt



REF: 56899  
Starter Kit

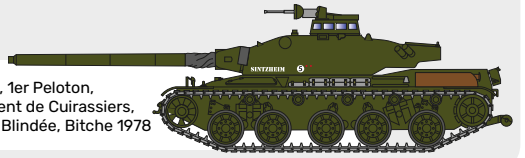

1er Escadron, 1er Peloton,  
4ème Régiment de Cuirassiers,  
1ère Division Blindée, Bitche 1978

1976 2020



REF: 79898

**VAB 4X4**

Scale: 1/72

<b>Année de fabrication</b> Year of construction - Baujahr	1991
<b>Quantité produite</b> Built quantity - Gebaute Menge	5.000
<b>Moteur</b> Engine - Motor	Renault MIDS 062045 Diesel
<b>Canon</b> Cannon - Kanone	1 x 7,62 - mm - Machine gun AA-52
<b>Poids</b> Weight - Gewicht	13 t

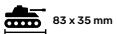

39 pieces

**VAB 4X4**

REF: 79898  
Plus d'informations  
More about this product  
Mehr zu diesem Produkt



REF: 56898  
Starter Kit

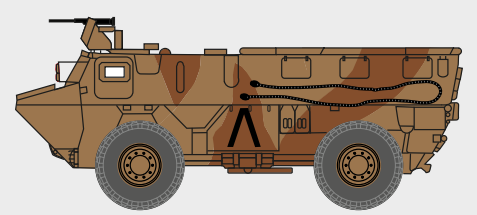
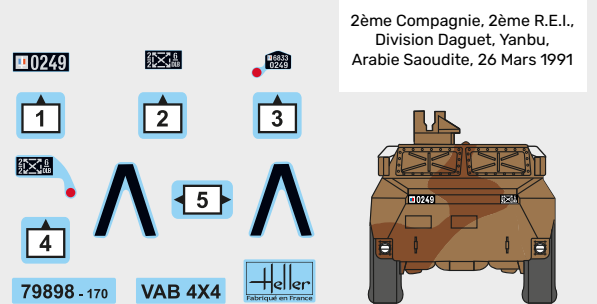

2005 2021

## SAINTE-MÈRE-EGLISE

REF: 50327  
Plus d'informations  
More about this product  
Mehr zu diesem Produkt



REF: 52327  
Starter Kit

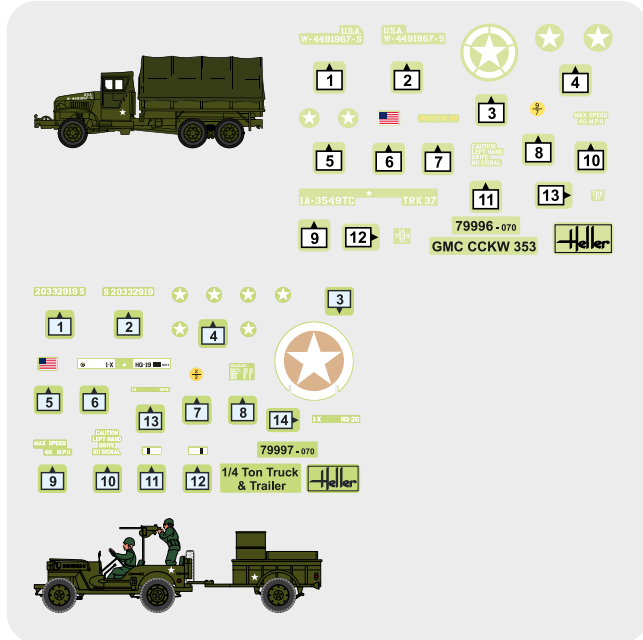

2004 2021 2012 2021 2012 2021

## OMAHA BEACH

REF: 50332  
Plus d'informations  
More about this product  
Mehr zu diesem Produkt



REF: 52332  
Starter Kit



2004 2021 2013 2020 2013 2021



REF: 50327 **SAINTE-MÈRE-EGLISE** Scale: 1/72

	GMC CCKW 353	US 1/4 TON TRUCK & TRAILER
<b>Année de fabrication</b> Year of construction - Baujahr	1941	1941
<b>Quantité produite</b> Built quantity - Gebaute Menge	800.000	640.000
<b>Puissance</b> Power - Leistung	104 CV/PS	60 CV/PS
<b>Vitesse maximale</b> Max. Speed - Max. Geschwindigkeit	71 km/h	105 km/h
<b>Longueur totale</b> Total length - Gesamtlänge	6,93 m	3,36 m
2x  96 x 33 mm 85 x 27 mm	48x  25 mm	169 pieces
2 x Decorations provided		



REF: 50332 **OMAHA BEACH** Scale: 1/72

	LCVP LANDING CRAFT VEHICLE & PERSONAL	M4 SHERMAN D-DAY	
<b>Année de fabrication</b> Year of construction - Baujahr	1941	1942	
<b>Quantité produite</b> Built quantity - Gebaute Menge	20.000	6.748	
<b>Moteur</b> Engine - Motor	Gray Marine diesel	Continental R975 C1	
<b>Canon</b> Cannon - Kanone	2 x .30 Cal	1 x 75 mm	
<b>Poids</b> Weight - Gewicht	12,4 t / 8,5 t	30.300 kg	
150 x 46 mm	87 x 37 mm	28x  25 mm	267 pieces
5 x Decorations provided			



REF: 81223

**FRENCH MOUNTAIN TROOPS**

Scale: 1/35

**Nation**  
Nation - Nation

France

50 mm

76 pieces

**FRENCH MOUNTAIN TROOPS**

REF: 81223  
Plus d'informations  
More about this product  
Mehr zu diesem Produkt



REF: 57223  
Starter Kit



**NEW**

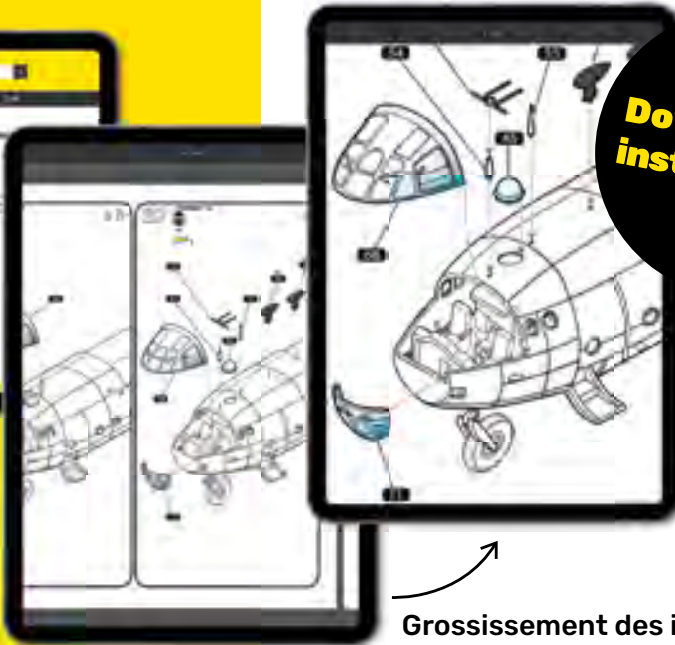

**Download all instructions!**

Choisissez l'article désiré et téléchargez la notice de montage.

Choose your desired article and download the instructions.

Wählen Sie den gewünschten Artikel und laden Sie die Anleitung herunter.

Grossissement des instructions pour une vue détaillée.

Enlarge the instructions for a more detailed view.

Vergrößern Sie die Anleitung für eine detailliertere Ansicht.

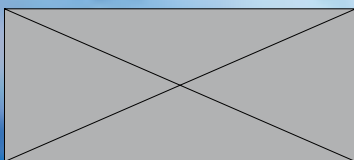

# GRAND APPEARANCE FOR MAJESTIC SAILING SHIPS!

HMS Victory and Soleil royal now come with completely updated building instructions. Shipped now with every box. Also available separately.

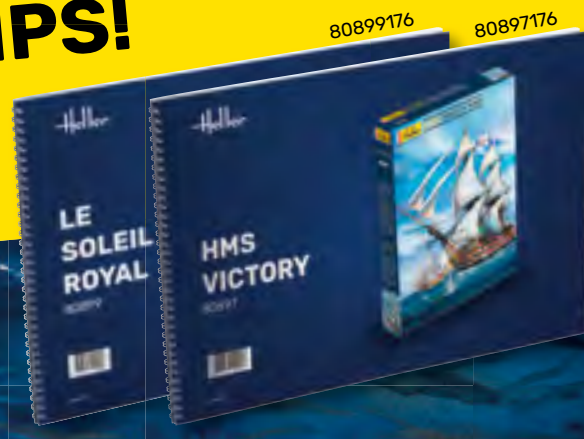



PREVIEW

Heller

REF: 81256

**DIORAMA  
CITIES OF EUROPE**

Scale:  
1/18 - 1/24

**Nation**

Nation - Nation

Europe

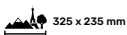

4 x Decorations provided

**DIORAMA CITIES OF EUROPE**

REF: 81256

Plus d'informations  
More about this product  
Mehr zu diesem Produkt



REF: 56795

Starter Kit



NEW  
TOOL



Heller



REF: 81253

**DIORAMA  
PISTE DESERT**

Scale:  
1/43 - 1/72

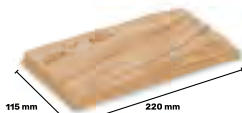

N° 81253 - DIORAMA PISTE DESERT

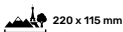

**DIORAMA PISTE DESERT**

REF: 81253

Plus d'informations  
More about this product  
Mehr zu diesem Produkt

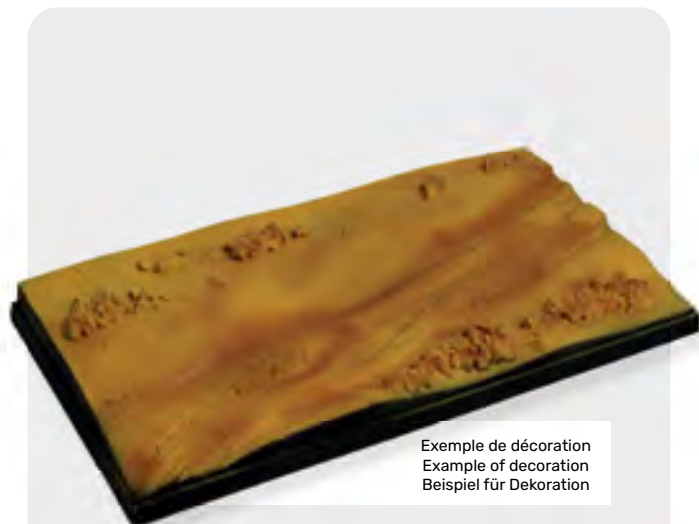

Exemple de décoration  
Example of decoration  
Beispiel für Dekoration

2005

## DIORAMA NORMANDIE

REF: 81250  
Plus d'informations  
More about this product  
Mehr zu diesem Produkt



Caen 1 Rouen 2 St Lô 2 Lisieux 3 Cherbourg 3 Paris  
57 km 129 km 101 km 50 km 115 km 210 km  
16 17 18  
hauptverbandpl. + Feldlazarett A.K.P. 536  
19 20 21 MANCHE  
ROAD CLEARED OF MINES TO HEDGES Minengasse O. Qu. West 13 ORNE  
22 23 24 14  
X Stalingrad 75 km Umgehungstrasse Cherbourg West Mines! Minen!  
ARROMANCHES BAYEUX LISIEUX FALAISE CAEN S' LÔ N.176 N.158  
9 4 8 10 12 7 11 15 5 6  
**AVRANCHES ARGENTAN**  
81250-070 DIORAMA RUINES NORMANDIE Heller

1987 2021

## DIORAMA CAMPAGNE

REF: 81254  
Plus d'informations  
More about this product  
Mehr zu diesem Produkt



Exemple de décoration  
Example of decoration  
Beispiel für Dekoration

1987 2020

Heller

REF: 81250 **DIORAMA NORMANDIE** Scale: 1/35

Nation: France

220 mm 59 pieces

Heller

REF: 81254 **DIORAMA CAMPAGNE** Scale: 1/24 - 1/35

235 mm 342 mm  
N° 81254 - DIORAMA CAMPAGNE

342 x 235 mm



REF: 81255

**DIORAMA  
DESERT**

Scale:  
1/24 - 1/35



N° 81255 - DIORAMA DESERT

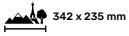

**DIORAMA DESERT**

**REF: 81255**

Plus d'informations  
More about this product  
Mehr zu diesem Produkt



Exemple de décoration  
Example of decoration  
Beispiel für Dekoration

1987 2020



REF: 81257

**CONCRETE  
PAVING SLABS**

Scale:  
1/24 - 1/72

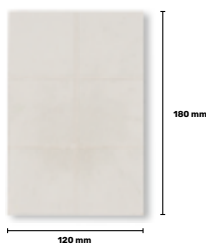

**CONCRETE PAVING SLABS**

**REF: 81257**

Plus d'informations  
More about this product  
Mehr zu diesem Produkt

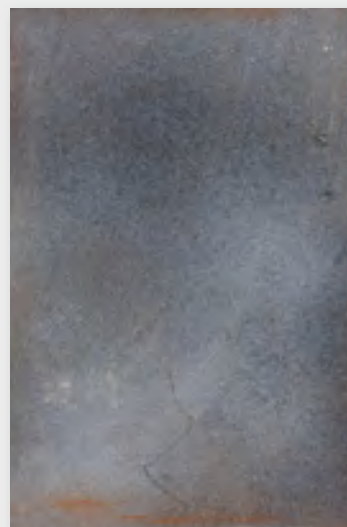

Exemple de décoration  
Example of decoration  
Beispiel für Dekoration



# Heller

ADVERTISEMENT

Distributed by  
**GLOW2B**  
germany



## SMALL VAN - HIGH ROOF!

**NEW**



More about  
this product



**RENAULT ESTAFETTE HIGHROOF**  
REF: 80740

Scale: 1/24 | 159 Pieces

 160 x 74 mm

3 x Decorations provided

2 IN 1 (1964/1973)

Heller



REF: 49609 **BRITISH INFANTRY 8TH ARMY** Scale: 1/72

Nation: United Kingdom

25 mm 49 pieces

**REF: 49609**  
Plus d'informations  
More about this product  
Mehr zu diesem Produkt



Heller



REF: 49632 **BRITISH COMMANDOS** Scale: 1/72

Nation: United Kingdom

25 mm 50 pieces

**REF: 49632**  
Plus d'informations  
More about this product  
Mehr zu diesem Produkt



Heller



REF: 49623 **BRITISH PARATROOPERS** Scale: 1/72

Nation: United Kingdom

25 mm 50 pieces

**REF: 49623**  
Plus d'informations  
More about this product  
Mehr zu diesem Produkt



Heller



REF: 49655 **GERMAN AIR FORCE PERSONNEL** Scale: 1/72

Nation: Germany

25 mm 48 pieces

**REF: 49655**  
Plus d'informations  
More about this product  
Mehr zu diesem Produkt



Heller



REF: 49602 **FRENCH INFANTRY** Scale: 1/72

Nation: France

25 mm 50 pieces

**REF: 49602**  
Plus d'informations  
More about this product  
Mehr zu diesem Produkt



Heller



REF: 49605 **GERMAN INFANTRY** Scale: 1/72

Nation: Germany

25 mm 48 pieces

**REF: 49605**  
Plus d'informations  
More about this product  
Mehr zu diesem Produkt





REF: 49606 **GERMAN PANZERGRENADIERS** Scale: 1/72

Nation  
Nation - Nation Germany

25 mm

48 pieces

**REF: 49606**  
Plus d'informations  
More about this product  
Mehr zu diesem Produkt



REF: 49604 **BRITISH INFANTRY** Scale: 1/72

Nation  
Nation - Nation United Kingdom

25 mm

50 pieces

**REF: 49604**  
Plus d'informations  
More about this product  
Mehr zu diesem Produkt



REF: 49603 **RUSSIAN INFANTRY** Scale: 1/72

Nation  
Nation - Nation Russian

25 mm

50 pieces

**REF: 49603**  
Plus d'informations  
More about this product  
Mehr zu diesem Produkt

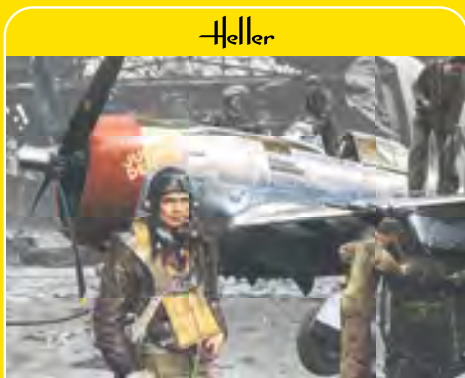

REF: 49648 **US AIR FORCE PERSONNEL** Scale: 1/72

Nation  
Nation - Nation USA

25 mm

46 pieces

**REF: 49648**  
Plus d'informations  
More about this product  
Mehr zu diesem Produkt



REF: 49651 **US PARATROOPERS** Scale: 1/72

Nation  
Nation - Nation USA

25 mm

46 pieces

**REF: 49651**  
Plus d'informations  
More about this product  
Mehr zu diesem Produkt

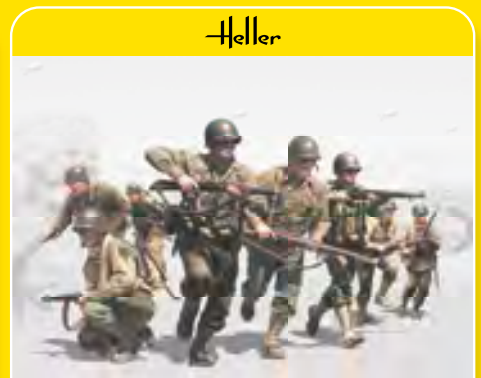

REF: 49601 **US INFANTRY** Scale: 1/72

Nation  
Nation - Nation USA

25 mm

50 pieces

**REF: 49601**  
Plus d'informations  
More about this product  
Mehr zu diesem Produkt





Heller



# AVIATION CIVILE

CIVIL AVIATION  
ZIVILE LUFTFAHRT

# CANADAIR CL-415

**[FRANÇAIS]** Le 9 février 1995, la Sécurité Civile reçoit le premier CL-415. Au premier coup d'oeil on le différencie grâce à ses ailettes. Mais sa plus grande particularité est sans conteste la nouvelle motorisation par deux turbopropulseurs qui remplacent les moteurs à pistons du 215. La rapidité d'action du Canadair est due au fait qu'il peut remplir ses soutes sur le plan d'eau le plus proche, l'écopage se faisant par hydroplanage à la vitesse de 110 km/h.

**[ENGLISH]** The French "Sécurité Civile" took delivery of the first CL-415 on the 9th February 1995. It was immediately distinguishable thanks to the fins mounted on the wingtips and the additional fins on the tail. However the biggest difference over its propeller powered predecessor the 215 was the two new turboprop engines. The efficiency and rapidity of the Canadair is due to the fact that it can reload with water on the nearest available sheet of water, in which case the water is scooped in by hydroplaning at a speed of 110kph.







REF: 80370
**CANADAIR CL-415**
Scale: 1/72

<b>Année de fabrication</b>	1995
Year of construction • Baujahr	
<b>Quantité produite</b>	76
Built quantity • Gebaute Menge	
<b>Puissance</b>	2 x 2.380 CV/PS
Power • Leistung	
<b>Vitesse maximale</b>	376 km/h
Max. Speed • Max. Geschwindigkeit	
<b>Envergure</b>	28,61 m
Wing span • Flügelspannweite	

276 x 397 mm
108 pieces

**[DEUTSCH]** Die französische „Sécurité Civile“ (Technisches Hilfswerk in Frankreich) erhielt am 9. Februar 1995 die erste CL-415. Sie war an den Luftstabilisatoren der Flügelspitzen zu erkennen. Der größte Unterschied, gegenüber der propellergetriebenen Vorgängerin 215, waren die beiden neuen Turboprop-Triebwerke. Die Effizienz und Schnelligkeit der Canadair war darauf zurückzuführen, dass sie auf einer nächstgelegenen großen Wasserfläche nachtanken konnte. Mit einer Geschwindigkeit von 110 Stundenkilometern konnte das Wasser durch Aquaplaning aufgenommen werden.



**REF: 80370**  
 Plus d'informations  
 More about this product  
 Mehr zu diesem Produkt



**REF: 56370**  
 Starter Kit



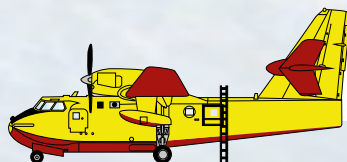

N° "39", Sécurité Civile  
Marseille-Marignane, 1997



REF: 30410

**PILATUS PC-6 B2/  
H2 TURBO PORTER**

Scale: 1/48

<b>Année de fabrication</b> Year of construction • Baujahr	1959
<b>Quantité produite</b> Built quantity • Gebaute Menge	1 Pratt Whitney Canada PT6A-27
<b>Puissance</b> Power • Leistung	680 CV/PS
<b>Vitesse maximale</b> Max. Speed • Max. Geschwindigkeit	280 km/h
<b>Envergure</b> Wing span • Flügelspannweite	15,20 m

 229 x 317 mm      2 x Decorations provided      163 pieces

**PILATUS PC-6 B2/ H2 TURBO PORTER**

**REF: 30410**  
Plus d'informations  
More about this product  
Mehr zu diesem Produkt



**REF: 35410**  
Starter Kit



PILATUS PC 6 B2/H2-H4 Turbo Porter, V-635, S/N 761, 7ème Escadron de transport, Forces aériennes suisses, Emmen, 2020



PILATUS PC-6/B2-H2M Turbo Porter, F-GFUM, S/N 740, Ecole de Parachutisme Sportif de la Moselle, Doncourt-lès-Confians, France, été 2020

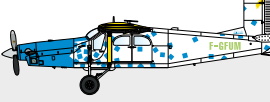



REF: 80490

**AS350 B3 ECUREUIL**

Scale: 1/48

<b>Année de fabrication</b> Year of construction • Baujahr	2005
<b>Puissance</b> Power • Leistung	738 CV/PS
<b>Vitesse maximale</b> Max. Speed • Max. Geschwindigkeit	287 km/h
<b>Envergure</b> Wing span • Flügelspannweite	Ø 10,96m

 260 x 214 mm      44 pieces

**AS350 B3 ECUREUIL**

**REF: 80490**  
Plus d'informations  
More about this product  
Mehr zu diesem Produkt



**REF: 56490**  
Starter Kit



**NEW  
DECAL**



1981 2023



## LOCKHEED L-749 CONSTELLATION AIR FRANCE

REF: 80310  
Plus d'informations  
More about this product  
Mehr zu diesem Produkt



REF: 56310  
Starter Kit

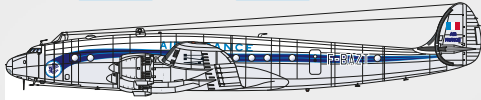
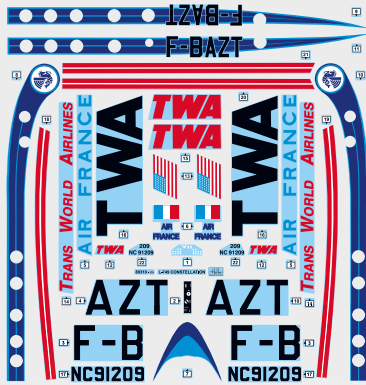

Air France

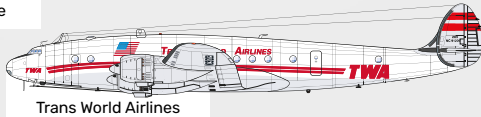

Trans World Airlines

1982 2020

## LOCKHEED L-749 CONSTELLATION „FLYING DUTCHMAN“

REF: 80393  
Plus d'informations  
More about this product  
Mehr zu diesem Produkt



REF: 56393  
Starter Kit

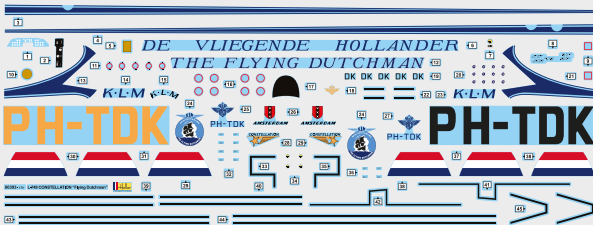

L-749 PH-TDK „Amsterdam“,  
9 novembre 1948

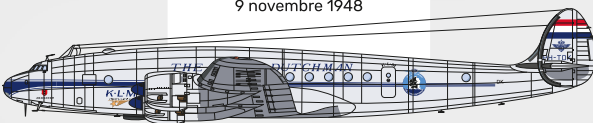

1982 2020



### LOCKHEED L-749 CONSTELLATION AIR FRANCE

REF: 80310

Scale: 1/72

<b>Année de fabrication</b> Year of construction • Baujahr	1943
<b>Quantité produite</b> Built quantity • Gebaute Menge	59
<b>Puissance</b> Power • Leistung	4 x 2.535 CV/PS
<b>Vitesse maximale</b> Max. Speed • Max. Geschwindigkeit	555 km/h
<b>Envergure</b> Wing span • Flügelspannweite	37,49 m

403 x 521 mm    2 x Decorations provided    91 pieces



### LOCKHEED L-749 CONSTELLATION „FLYING DUTCHMAN“

REF: 80393

Scale: 1/72

<b>Année de fabrication</b> Year of construction • Baujahr	1947
<b>Quantité produite</b> Built quantity • Gebaute Menge	59
<b>Puissance</b> Power • Leistung	4 x 2.535 CV/PS
<b>Vitesse maximale</b> Max. Speed • Max. Geschwindigkeit	555 km/h
<b>Envergure</b> Wing span • Flügelspannweite	37,49 m

403 x 521 mm    91 pieces



Heller

PREVIEW

REF: 80315

**DC6 SUPER CLOUDMASTER AF**

Scale: 1/72

<b>Année de fabrication</b> Year of construction • Baujahr	1952
<b>Quantité produite</b> Built quantity • Gebaute Menge	286
<b>Puissance</b> Power • Leistung	2400 CV/PS
<b>Vitesse maximale</b> Max. Speed • Max. Geschwindigkeit	580 km/h
<b>Envergure</b> Wing span • Flügelspannweite	35,81 m

 447 x 488 mm 103 pieces

**DC6 SUPER CLOUDMASTER AF**

REF: 80315  
Plus d'informations  
More about this product  
Mehr zu diesem Produkt



REF: 56315  
Starter Kit



NEW  
DECAL



1984 2023



Heller

PREVIEW

REF: 82391

**SUPER CONSTELLATION TWA**

Scale: 1/72

<b>Année de fabrication</b> Year of construction • Baujahr	1951
<b>Quantité produite</b> Built quantity • Gebaute Menge	102
<b>Puissance</b> Power • Leistung	3250 CV/PS
<b>Vitesse maximale</b> Max. Speed • Max. Geschwindigkeit	482 km/h
<b>Envergure</b> Wing span • Flügelspannweite	37,50 m

 478 x 520 mm 97 pieces

**SUPER CONSTELLATION TWA**

REF: 82391  
Plus d'informations  
More about this product  
Mehr zu diesem Produkt



REF: 58391  
Starter Kit



NEW  
DECAL



1985 2023

## DORNIER DO 27/CASA C-127

**REF: 30304**  
Plus d'informations  
More about this product  
Mehr zu diesem Produkt



**REF: 35304**  
Starter Kit



REF: 30304 **DORNIER DO 27/CASA C-127** Scale: 1/72

<b>Année de fabrication</b> Year of construction - Baujahr	1955
<b>Quantité produite</b> Built quantity - Gebaute Menge	677
<b>Puissance</b> Power - Leistung	270 CV / PS
<b>Vitesse maximale</b> Max. Speed - Max. Geschwindigkeit	248 km/h
<b>Envergure</b> Wing span - Flügelspannweite	12.00 m
133 x 167 mm	4 x Decorations provided
	72 pieces

## BOEING B-707

**REF: 80452**  
Plus d'informations  
More about this product  
Mehr zu diesem Produkt



**REF: 56452**  
Starter Kit

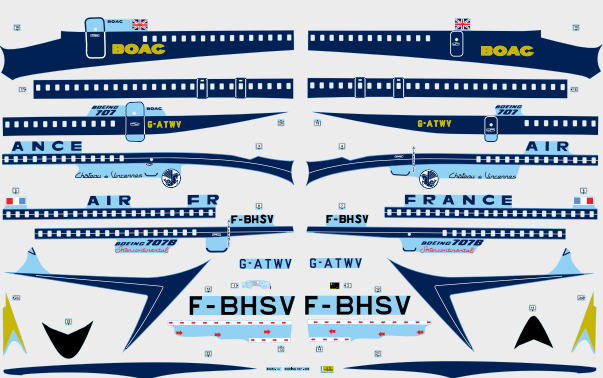

REF: 80452 **BOEING B-707** Scale: 1/72

<b>Année de fabrication</b> Year of construction - Baujahr	1957
<b>Quantité produite</b> Built quantity - Gebaute Menge	865
<b>Puissance</b> Power - Leistung	4 x 75,99 kN
<b>Vitesse maximale</b> Max. Speed - Max. Geschwindigkeit	885-974 km/h
<b>Envergure</b> Wing span - Flügelspannweite	44,40 m
647 x 617 mm	2 x Decorations provided
	105 pieces

1986 2021



REF: 80469

**CONCORDE  
AIR FRANCE**

Scale: 1/72

<b>Année de fabrication</b> Year of construction · Baujahr	1967
<b>Quantité produite</b> Built quantity · Gebaute Menge	20
<b>Puissance</b> Power · Leistung	140 kN (dry) / 169,3 kN with afterburner each
<b>Vitesse maximale</b> Max. Speed · Max. Geschwindigkeit	Mach 2,05
<b>Envergure</b> Wing span · Flügelspannweite	25,60 m

865 x 355 mm    5 x Decorations provided    151 pieces

**CONCORDE AIR FRANCE**

REF: 80469  
Plus d'informations  
More about this product  
Mehr zu diesem Produkt



REF: 56469  
Starter Kit

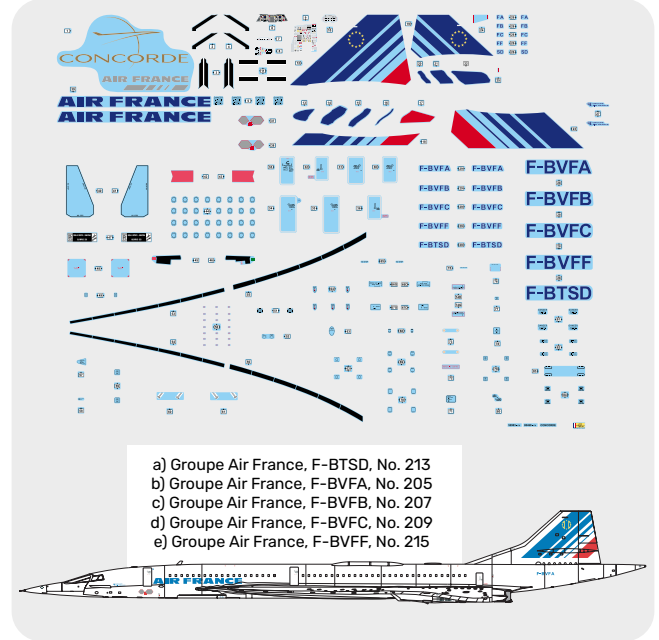

- a) Groupe Air France, F-BTSD, No. 213
- b) Groupe Air France, F-BVFA, No. 205
- c) Groupe Air France, F-BVFB, No. 207
- d) Groupe Air France, F-BVFC, No. 209
- e) Groupe Air France, F-BVFF, No. 215

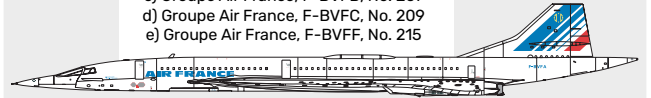

**CANADAIR CL-215**

REF: 80373  
Plus d'informations  
More about this product  
Mehr zu diesem Produkt



REF: 56373  
Starter Kit



REF: 80373

**CANADAIR CL-215**

Scale: 1/72

<b>Année de fabrication</b> Year of construction · Baujahr	1989
<b>Quantité produite</b> Built quantity · Gebaute Menge	125
<b>Puissance</b> Power · Leistung	2 x 2,129 CV/PS
<b>Vitesse maximale</b> Max. Speed · Max. Geschwindigkeit	291 km/h
<b>Envergure</b> Wing span · Flügelspannweite	28,60 m

276 x 397 mm    4 x Decorations provided    100 pieces

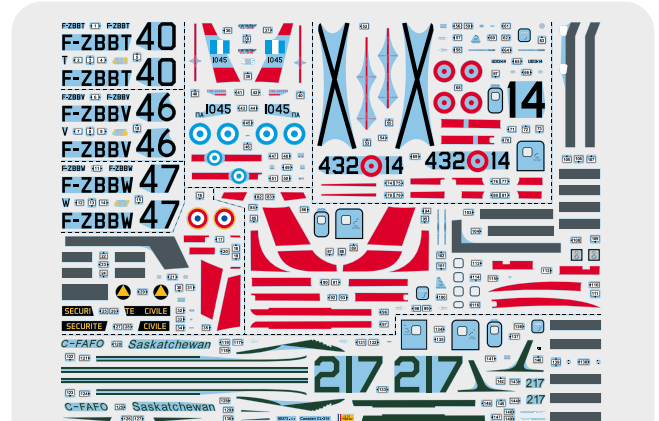

France: F-ZBBV, "Pélican 47"  
Sécurité Civile,  
1976 - 1996



Espagne: UD13-13, Ejército  
del Aire 432-14, Septiembre  
1993



Grèce: N°1045, Hellenic  
Air Force, Novembre 2014



Canada: N°217, C-FAFO,  
Province du Saskatchewan,  
2010



## AEROSPATIALE SA 316B ALOUETTE III GENDARMERIE

**REF: 80286**  
Plus d'informations  
More about this product  
Mehr zu diesem Produkt



**REF: 56286**  
Starter Kit



N°1098 „JBF“, G.C.F.A. Gendarmerie, mars 1994  
 N°2330 „JBY“, Dernier vol, Lyon-Bron, 19 octobre 2009

designé pour Heller par FFSMC Productions Alouette III Gendarmerie 50-80286-070

1989 2021

## AEROSPATIALE SA 316B ALOUETTE III SÉCURITÉ CIVILE

**REF: 80289**  
Plus d'informations  
More about this product  
Mehr zu diesem Produkt



**REF: 56289**  
Starter Kit



N°2306 "AW", "Sécurité Civile", Annecy, Décembre 1994  
 N°1611 „F-GUAD“, „Conseil général de l'Hérault, sapeurs pompiers“, Montpellier, Juillet 2006

designé pour Heller par FFSMC Productions 80289-001 ALOUETTE III Sécurité Civile

1989 2021

### AEROSPATIALE SA 316B ALOUETTE III GENDARMERIE

REF: 80286 Scale: 1/72

<b>Année de fabrication</b> Year of construction - Baujahr	1968
<b>Quantité produite</b> Built quantity - Gebaute Menge	1.472
<b>Puissance</b> Power - Leistung	870 CV/PS
<b>Vitesse maximale</b> Max. Speed - Max. Geschwindigkeit	185 km/h - 210 km/h
<b>Envergure</b> Wing span - Flügelspannweite	Ø 11,02 m

178 x 161 mm    2 x Decorations provided    66 pieces

### AEROSPATIALE SA 316B ALOUETTE III SÉCURITÉ CIVILE

REF: 80289 Scale: 1/72

<b>Année de fabrication</b> Year of construction - Baujahr	1968
<b>Quantité produite</b> Built quantity - Gebaute Menge	1.472
<b>Puissance</b> Power - Leistung	870 CV/PS
<b>Vitesse maximale</b> Max. Speed - Max. Geschwindigkeit	210 km/h
<b>Envergure</b> Wing span - Flügelspannweite	Ø 11,02 m

178 x 161 mm    2 x Decorations provided    72 pieces

Heller



REF: 80459

**B-747 AF**

Scale: 1/125

<b>Année de fabrication</b> Year of construction • Baujahr	1966
<b>Quantité produite</b> Built quantity • Gebaute Menge	168
<b>Puissance</b> Power • Leistung	Takeoff thrust 193–230 kN
<b>Vitesse maximale</b> Max. Speed • Max. Geschwindigkeit	939 km/h
<b>Envergure</b> Wing span • Flügelspannweite	59,60 m

565 x 477 mm      2 x Decorations provided      139 pieces

**B-747 AF**

**REF: 80459**  
Plus d'informations  
More about this product  
Mehr zu diesem Produkt



**REF: 56459**  
Starter Kit

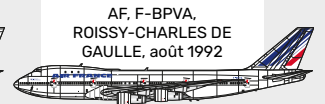
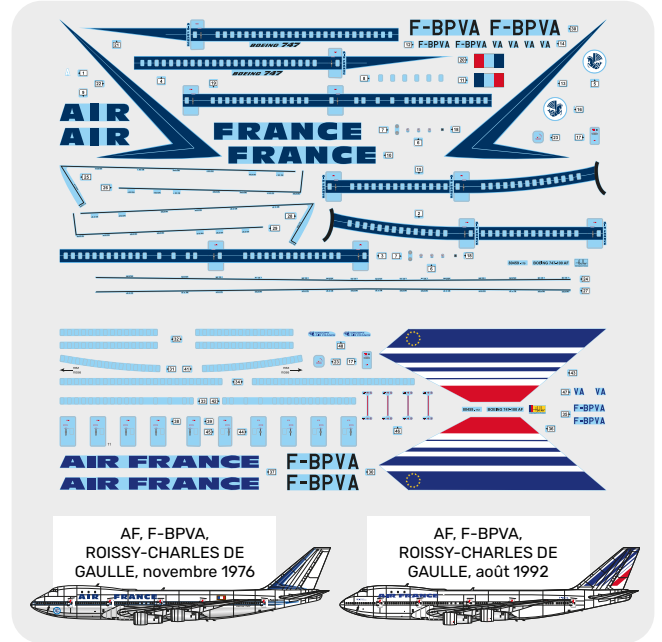

1971 2021

Heller



REF: 80445

**CONCORDE AIR FRANCE**

Scale: 1/125

<b>Année de fabrication</b> Year of construction • Baujahr	1967
<b>Quantité produite</b> Built quantity • Gebaute Menge	20
<b>Puissance</b> Power • Leistung	140 kN (dry) / 169,3 kN with afterburner each
<b>Vitesse maximale</b> Max. Speed • Max. Geschwindigkeit	Mach 2,05
<b>Envergure</b> Wing span • Flügelspannweite	25,6 m

494 x 208 mm      85 pieces

**CONCORDE AIR FRANCE**

**REF: 80445**  
Plus d'informations  
More about this product  
Mehr zu diesem Produkt



**REF: 56445**  
Starter Kit



1977 2020

## A320 AF

**REF: 80448**  
Plus d'informations  
More about this product  
Mehr zu diesem Produkt



**REF: 56448**  
Starter Kit

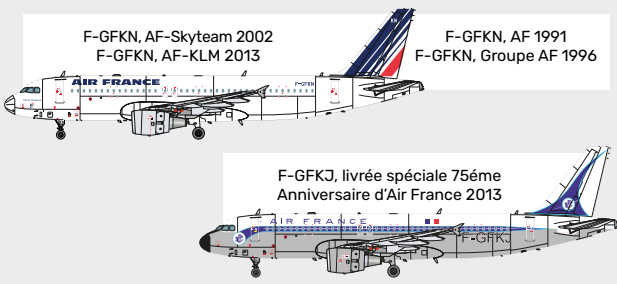
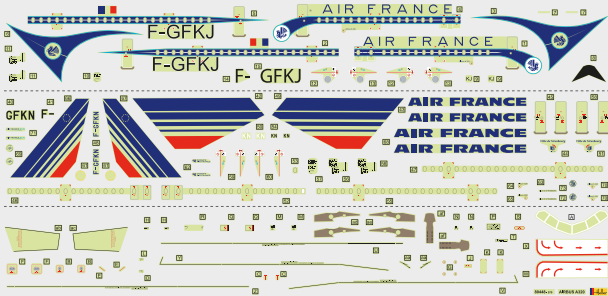

**1989** **2021**

## A380 AF

**REF: 80436**  
Plus d'informations  
More about this product  
Mehr zu diesem Produkt



**REF: 56436**  
Starter Kit

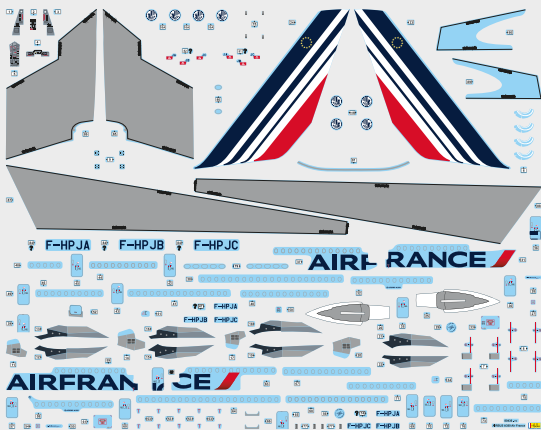

**2006** **2021**



REF: 80448

**A320 AF**

Scale: 1/125

<b>Année de fabrication</b> Year of construction • Baujahr	1987
<b>Quantité produite</b> Built quantity • Gebaute Menge	16.214
<b>Puissance</b> Power • Leistung	9.980 kgp
<b>Vitesse maximale</b> Max. Speed • Max. Geschwindigkeit	871 km/h
<b>Envergure</b> Wing span • Flügelspannweite	34,10 m

301 x 271 mm    5 x Decorations provided    34 pieces



REF: 80436

**A380 AF**

Scale: 1/125

<b>Année de fabrication</b> Year of construction • Baujahr	2009
<b>Quantité produite</b> Built quantity • Gebaute Menge	249
<b>Puissance</b> Power • Leistung	311 kN
<b>Vitesse maximale</b> Max. Speed • Max. Geschwindigkeit	919 km/h
<b>Envergure</b> Wing span • Flügelspannweite	79,80 m

582 x 638 mm    3 x Decorations provided    239 pieces



Heller

REF: 80441

**ARIANE 5**

Scale: 1/125

<b>Année de fabrication</b> Year of construction • Baujahr	1998
<b>Quantité produite</b> Built quantity • Gebaute Menge	65
<b>Puissance</b> Power • Leistung	11.500 kN
<b>Vitesse maximale</b> Max. Speed • Max. Geschwindigkeit	5,55 m/s2
<b>Envergure</b> Wing span • Flügelspannweite	51,49 m (e 5,50 m)

460 x ø 106 mm

40 pieces

**ARIANE 5**

REF: 80441  
Plus d'informations  
More about this product  
Mehr zu diesem Produkt



REF: 56441  
Starter Kit



arianespace arianespace 5

1 2 3 4

esa esa esa esa

cnes cnes cnes cnes

80441 - 170  
ARIANE 5

France : Kourou 1998

1998 2021

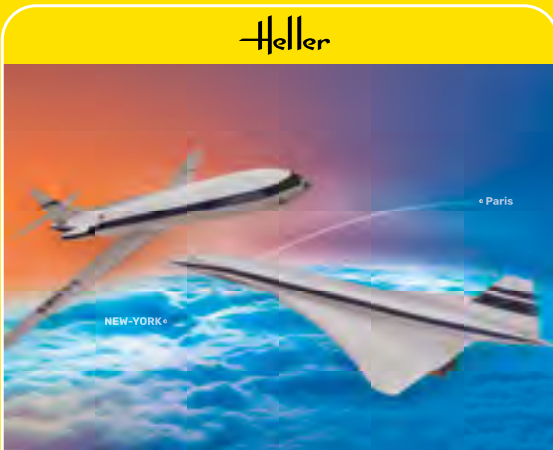

Heller

REF: 50333

**CARAVELLE + CONCORDE**

Scale: 1/100

	Caravelle	Concorde
<b>Année de fabrication</b> Year of construction • Baujahr	1959	1968
<b>Quantité produite</b> Built quantity • Gebaute Menge	282	20
<b>Puissance</b> Power • Leistung	47 kN	140 kN (dry) / 169,3 kN with afterburner each
<b>Vitesse maximale</b> Max. Speed • Max. Geschwindigkeit	746 km/h	Mach 2,05
<b>Envergure</b> Wing span • Flügelspannweite	34,3 m	23,8 m

322 x 342 mm  
518 x 238 mm

2 x 2 Decorations provided

182 pieces

**CARAVELLE + CONCORDE**

REF: 50333  
Plus d'informations  
More about this product  
Mehr zu diesem Produkt



REF: 52333  
Starter Kit



F-B F-BHRA HRA F-BHHIF-B HHI

3 4 5 6 7 8 9 10 11 12 13 14 15 16 17 18 19 20 21 22 23 24 25 26 27 28 29 30 31 32 33 34 35 36 37 38 39 40 41 42 43 44 45 46 47 48 49 50 51 52 53 54 55 56 57 58 59 60 61 62 63 64 65 66 67 68 69 70 71 72 73 74 75 76 77 78 79 80 81 82 83 84 85 86 87 88 89 90 91 92 93 94 95 96 97 98 99 100 101 102 103 104 105 106 107 108 109 110 111 112 113 114 115 116 117 118 119 120 121 122 123 124 125 126 127 128 129 130 131 132 133 134 135 136 137 138 139 140 141 142 143 144 145 146 147 148 149 150 151 152 153 154 155 156 157 158 159 160 161 162 163 164 165 166 167 168 169 170 171 172 173 174 175 176 177 178 179 180 181 182 183 184 185 186 187 188 189 190 191 192 193 194 195 196 197 198 199 200 201 202 203 204 205 206 207 208 209 210 211 212 213 214 215 216 217 218 219 220 221 222 223 224 225 226 227 228 229 230 231 232 233 234 235 236 237 238 239 240 241 242 243 244 245 246 247 248 249 250 251 252 253 254 255 256 257 258 259 260 261 262 263 264 265 266 267 268 269 270 271 272 273 274 275 276 277 278 279 280 281 282 283 284 285 286 287 288 289 290 291 292 293 294 295 296 297 298 299 300 301 302 303 304 305 306 307 308 309 310 311 312 313 314 315 316 317 318 319 320 321 322 323 324 325 326 327 328 329 330 331 332 333 334 335 336 337 338 339 340 341 342 343 344 345 346 347 348 349 350 351 352 353 354 355 356 357 358 359 360 361 362 363 364 365 366 367 368 369 370 371 372 373 374 375 376 377 378 379 380 381 382 383 384 385 386 387 388 389 390 391 392 393 394 395 396 397 398 399 400 401 402 403 404 405 406 407 408 409 410 411 412 413 414 415 416 417 418 419 420 421 422 423 424 425 426 427 428 429 430 431 432 433 434 435 436 437 438 439 440 441 442 443 444 445 446 447 448 449 450 451 452 453 454 455 456 457 458 459 460 461 462 463 464 465 466 467 468 469 470 471 472 473 474 475 476 477 478 479 480 481 482 483 484 485 486 487 488 489 490 491 492 493 494 495 496 497 498 499 500 501 502 503 504 505 506 507 508 509 510 511 512 513 514 515 516 517 518 519 520 521 522 523 524 525 526 527 528 529 530 531 532 533 534 535 536 537 538 539 540 541 542 543 544 545 546 547 548 549 550 551 552 553 554 555 556 557 558 559 560 561 562 563 564 565 566 567 568 569 570 571 572 573 574 575 576 577 578 579 580 581 582 583 584 585 586 587 588 589 590 591 592 593 594 595 596 597 598 599 600 601 602 603 604 605 606 607 608 609 610 611 612 613 614 615 616 617 618 619 620 621 622 623 624 625 626 627 628 629 630 631 632 633 634 635 636 637 638 639 640 641 642 643 644 645 646 647 648 649 650 651 652 653 654 655 656 657 658 659 660 661 662 663 664 665 666 667 668 669 670 671 672 673 674 675 676 677 678 679 680 681 682 683 684 685 686 687 688 689 690 691 692 693 694 695 696 697 698 699 700 701 702 703 704 705 706 707 708 709 710 711 712 713 714 715 716 717 718 719 720 721 722 723 724 725 726 727 728 729 730 731 732 733 734 735 736 737 738 739 740 741 742 743 744 745 746 747 748 749 750 751 752 753 754 755 756 757 758 759 760 761 762 763 764 765 766 767 768 769 770 771 772 773 774 775 776 777 778 779 780 781 782 783 784 785 786 787 788 789 790 791 792 793 794 795 796 797 798 799 800 801 802 803 804 805 806 807 808 809 810 811 812 813 814 815 816 817 818 819 820 821 822 823 824 825 826 827 828 829 830 831 832 833 834 835 836 837 838 839 840 841 842 843 844 845 846 847 848 849 850 851 852 853 854 855 856 857 858 859 860 861 862 863 864 865 866 867 868 869 870 871 872 873 874 875 876 877 878 879 880 881 882 883 884 885 886 887 888 889 890 891 892 893 894 895 896 897 898 899 900 901 902 903 904 905 906 907 908 909 910 911 912 913 914 915 916 917 918 919 920 921 922 923 924 925 926 927 928 929 930 931 932 933 934 935 936 937 938 939 940 941 942 943 944 945 946 947 948 949 950 951 952 953 954 955 956 957 958 959 960 961 962 963 964 965 966 967 968 969 970 971 972 973 974 975 976 977 978 979 980 981 982 983 984 985 986 987 988 989 990 991 992 993 994 995 996 997 998 999 1000

FRANCE: CONCORDE, F-WTSS, Prototype n°1 + GRANDE BRETAGNE: CONCORDE, G-BSST, Prototype n°2

SE 210 CARAVELLE décoration HELLER originale, 1957 + SE 210 CARAVELLE F-BHHI, prototype n°2, 1957

1957 1964



# Heller

ADVERTISEMENT

Distributed by  
**GLOW2B**  
germany

## KEEP 'EM ROLLING, JIMMY!

The GMC CCKW 353:  
Backbone of the  
Red Ball Express



REF: 79996  
GMC CCKW 353

Scale: 1/72

66 Pieces



96 x 33 mm



[www.heller.fr](http://www.heller.fr) [info@heller.fr](mailto:info@heller.fr)

[instagram.com/heller.fr](https://www.instagram.com/heller.fr) [facebook.com/heller.fr](https://www.facebook.com/heller.fr) #legendarymodels





Heller

# AVIATION MILITAIRE

MILITARY AVIATION  
MILITÄRISCHE LUFTFAHRT

# E-2C HAWKEYE

**[FRANÇAIS]** Conçu par Grumman dès 1957 pour remplir des fonctions de surveillance à partir de porte-avions de façon totalement autonome, le E-2 Hawkeye n'a jusqu'à ce jour jamais cessé d'évoluer. Certainement le plus complexe des appareils embarqués actuels, ses dimensions généreuses ne l'empêchent pourtant pas de pouvoir descendre dans les hangars du porte-avions, la voilure se repliant latéralement de chaque côté du fuselage. Son coeur opérationnel est véritablement son radar, associé à un ordinateur des plus rapides. La Marine française a commandé trois exemplaires de la version la plus récente du Hawkeye en avril 1995. Le premier a été réceptionné sur la base de Lann-Bihoué le 18 décembre 1998. Ces appareils volent au sein de la Flottille 4F embarquée sur le PAN Charles de Gaulle.

**[ENGLISH]** Designed by Grumman as from 1957 to carry out surveillance missions from aircraft carriers in an entirely autonomous way, the E-2 Hawkeye has up to

now never ceased to develop. Certainly today's most complex aircraft ever to be loaded, its large dimensions however don't prevent it from going down into the hangars of the aircraft carrier, since the wings fold back laterally on each side of the fuselage. The operational core is in fact the radar, combined with a very high performance computer. The French Navy ordered three units of the most



recent model in April 1995. They took delivery of the first one on the 18th December 1998 at the Lann-Bihoué airbase. These aircraft are part of the 4F Flotilla and are aboard the Charles de Gaulle aircraft carrier.

**[DEUTSCH]** Das von Grumman bereits 1957 entworfene Flugzeug, wurde für die Überwachung von Flugzeugträgern aus unabhängig entwickelt und ist bis heute immer weiter entwickelt worden. Die Hawkeye ist mit Sicherheit das komplexeste Flugzeug, das es gibt. Sie ist so groß, dass sie trotzdem in der Lage ist, problemlos zu starten. Die Hawkeye kann in den Hangars der Flugzeugträger untergebracht werden, da sich die Flügel seitlich auf beiden Seiten zurückklappen lassen. Das operative Kernstück ist der Radar, der mit einem der schnellsten Rechner ausgestattet ist. Die französische Marine bestellte drei Exemplare der Hawkeye im April 1995. Das erste Exemplar wurde am 18. Dezember 1998 an den Luftwaffenstützpunkt Lann-Bihoué ausgeliefert. Diese Flugzeuge sind Teil der 4F-Flottille und befinden sich an Bord des Flugzeugträgers Charles de Gaulle.



NEW TOOL



REF: 82300
**E-2C HAWKEYE**
Scale: 1/72

<b>Année de fabrication</b> Year of construction • Baujahr	2000
<b>Quantité produite</b> Built quantity • Gebaute Menge	205
<b>Puissance</b> Power • Leistung	10.333 CV/PS
<b>Vitesse maximale</b> Max. Speed • Max. Geschwindigkeit	626 km/h
<b>Envergure</b> Wing span • Flügelspannweite	24,56 m

244 x 340 mm
199 pieces



**REF: 82300**  
Plus d'informations  
More about this product  
Mehr zu diesem Produkt



**REF: 58300**  
Starter Kit





Stotz



REF: 30510

**FOUGA MAGISTER CM 170**

Scale: 1/48

<b>Année de fabrication</b> Year of construction • Baujahr	1953
<b>Quantité produite</b> Built quantity • Gebaute Menge	1 009
<b>Puissance</b> Power • Leistung	480 kgp x 2
<b>Vitesse maximale</b> Max. Speed • Max. Geschwindigkeit	725 km/h
<b>Envergure</b> Wing span • Flügelspannweite	12,15 m

210 x 253 mm    3 x Decorations provided    170 pieces

**FOUGA MAGISTER CM 170**

**REF: 30510**  
Plus d'informations  
More about this product  
Mehr zu diesem Produkt



**REF: 35510**  
Starter Kit



France: Patrouille de France, BA 701, Salon de Provence, 1978

Belgium: Fouga Magister, MT 15 No 272

Germany: Bundesluftwaffe Flugzeugführerschule A, Landsberg, 1964



REF: 30520

**F-104G STARFIGHTER**

Scale: 1/48

<b>Année de fabrication</b> Year of construction • Baujahr	1954
<b>Quantité produite</b> Built quantity • Gebaute Menge	2.578
<b>Puissance</b> Power • Leistung	44,50 kN / 69,42 kN with PC
<b>Vitesse maximale</b> Max. Speed • Max. Geschwindigkeit	Mach 2.0 / 2200 km/h
<b>Envergure</b> Wing span • Flügelspannweite	6,68 m

372 x 162 mm    3 x Decorations provided    222 pieces

**F-104G STARFIGHTER**

**REF: 30520**  
Plus d'informations  
More about this product  
Mehr zu diesem Produkt



**REF: 35520**  
Starter Kit



USA, 63-13269, Luke AFB 58th TTW, 1982

Allemagne, 23+45 JG 71 „R“ Wittmund AB, 1973

Belgique, FX 74, MSN: 683-9126 Beauvechain 1981

## MIRAGE III E/RD

**REF: 30422**  
Plus d'informations  
More about this product  
Mehr zu diesem Produkt



**REF: 35422**  
Starter Kit



Mirage III E, No. 417, EC 2/13 „Alpes“, Colmar Meyerheim, April 1965

Mirage III RD, MSN: 370, Nato-Recce-Meet „Royal Flush XVIII“, Bremgarten AB, April 1974



REF: 30422 **MIRAGE III E/RD** Scale: 1/48

<b>Année de fabrication</b> Year of construction • Baujahr	1963
<b>Quantité produite</b> Built quantity • Gebaute Menge	1422
<b>Puissance</b> Power • Leistung	42 kN / 58,9 kN with PC
<b>Vitesse maximale</b> Max. Speed • Max. Geschwindigkeit	Mach 2.2 / 2335 km/h
<b>Envergure</b> Wing span • Flügelspannweite	8,22 m

313 x 171 mm      2 x Decorations provided      185 pieces

## MIRAGE IV P

**REF: 80493**  
Plus d'informations  
More about this product  
Mehr zu diesem Produkt



**REF: 56493**  
Starter Kit



1980 2023



REF: 80493 **MIRAGE IV P** Scale: 1/48

<b>Année de fabrication</b> Year of construction • Baujahr	1964
<b>Quantité produite</b> Built quantity • Gebaute Menge	62
<b>Puissance</b> Power • Leistung	66 kN
<b>Vitesse maximale</b> Max. Speed • Max. Geschwindigkeit	Mach 2.2
<b>Envergure</b> Wing span • Flügelspannweite	11,84 m

487 x 246 mm      2 x Decorations provided      80 pieces



**RE-  
RELEASE**

Heller

REF: 80427

**JAGUAR GR1/GR3**

Scale: 1/48

<b>Année de fabrication</b> Year of construction • Baujahr	1983
<b>Quantité produite</b> Built quantity • Gebaute Menge	543
<b>Puissance</b> Power • Leistung	37.400 kN
<b>Vitesse maximale</b> Max. Speed • Max. Geschwindigkeit	1750 km/h
<b>Envergure</b> Wing span • Flügelspannweite	8,69 m

350 x 181 mm    5 x Decorations provided 2 IN 1    128 pieces

**JAGUAR GR1/GR3**

**REF: 80427**  
Plus d'informations  
More about this product  
Mehr zu diesem Produkt



**REF: 56427**  
Starter Kit



JS197  
JS197  
JS197

GR1A XZ112/GA, 42 Squadron, Brize Norton, septembre 1991

GR3A XX112/EA, 6 Squadron Cothishall, octobre 2004

GR1A XX116, 16 Squadron, septembre 2004

GR1A XZ356 / "Mary Rose", 41 Squadron, Cothishall, mars 1991

IS JS197, 16 Squadron, Brize Norton, septembre 1991

80427 SEPECAT Jaguar GR.1A / GR.3A

1993 2023



Heller

REF: 80426

**MIRAGE 2000C**

Scale: 1/48

<b>Année de fabrication</b> Year of construction • Baujahr	1983
<b>Quantité produite</b> Built quantity • Gebaute Menge	611
<b>Puissance</b> Power • Leistung	64,3 kN / 95,1 kN with afterburner
<b>Vitesse maximale</b> Max. Speed • Max. Geschwindigkeit	Mach 2.3 / 2336 km/h
<b>Envergure</b> Wing span • Flügelspannweite	9,13 m

298 x 299 mm    2 x Decorations provided    92 pieces

**MIRAGE 2000 C**

**REF: 80426**  
Plus d'informations  
More about this product  
Mehr zu diesem Produkt



**REF: 56426**  
Starter Kit



5-OM

KF135

France: E.C. 2/5 „ILE DE FRANCE“, AL ASHA, ARABIE SAOUDITE, 1991

India: „Tigers Squadron“, KF 135, MAHARAJPURA AIR BASE, GWAILOR, 1991

80426 AIRBUS MIRA2000C

1992 2021



## F-16 DARK FALCON

REF: 30411

Plus d'informations  
More about this product  
Mehr zu diesem Produkt



REF: 35411

Starter Kit



**NEW  
TOOL**



2023

## SA 342 GAZELLE

REF: 80486

Plus d'informations  
More about this product  
Mehr zu diesem Produkt



REF: 56486

Starter Kit



**NEW  
DECAL**



1973 2023

Heller



REF: 30411

**F-16 DARK FALCON**

Scale: 1/48

<b>Année de fabrication</b> Year of construction • Baujahr	1976 / current
<b>Quantité produite</b> Built quantity • Gebaute Menge	4604
<b>Puissance</b> Power • Leistung	128,9 kN
<b>Vitesse maximale</b> Max. Speed • Max. Geschwindigkeit	Mach 2,02
<b>Envergure</b> Wing span • Flügelspannweite	9,45 m

318 x 190 mm

200 pieces

Heller

**PREVIEW**



REF: 80486

**SA 342 GAZELLE**

Scale: 1/48

<b>Année de fabrication</b> Year of construction • Baujahr	1985
<b>Puissance</b> Power • Leistung	870 CV/PS
<b>Vitesse maximale</b> Max. Speed • Max. Geschwindigkeit	280 km/h
<b>Envergure</b> Wing span • Flügelspannweite	Ø 10,5 m

249 x 241 mm

57 pieces

Heller



REF: 80380 **JUNKERS JU-52/3M** Scale: 1/72

<b>Année de fabrication</b> Year of construction • Baujahr	1932
<b>Quantité produite</b> Built quantity • Gebaute Menge	4845
<b>Puissance</b> Power • Leistung	3 x 725 CV/PS
<b>Vitesse maximale</b> Max. Speed • Max. Geschwindigkeit	277 km/h
<b>Envergure</b> Wing span • Flügelspannweite	29,25 m

 262 x 406 mm

101 pieces

## JUNKERS JU-52/3M

REF: 80380  
Plus d'informations  
More about this product  
Mehr zu diesem Produkt



REF: 56380  
Starter Kit

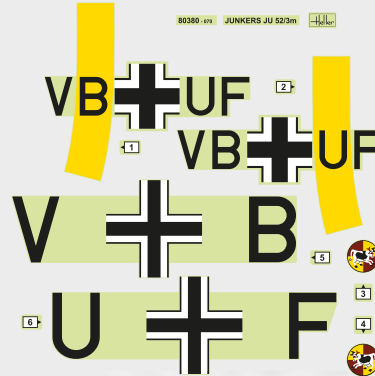

Allemagne: Ju 52/3m G6E Ecole de Pilotage sans Visibilité B36 - 1938

1979 2020

Heller



REF: 80238 **FOCKE WULF FW 56A-1 STÖSSER** Scale: 1/72

<b>Année de fabrication</b> Year of construction • Baujahr	1935
<b>Quantité produite</b> Built quantity • Gebaute Menge	1.000
<b>Puissance</b> Power • Leistung	240 CV/PS
<b>Vitesse maximale</b> Max. Speed • Max. Geschwindigkeit	278 km/h
<b>Envergure</b> Wing span • Flügelspannweite	10,50 m

 106 x 146 mm

3 x Decorations provided

34 pieces

## FOCKE WULF FW 56A-1 STÖSSER

REF: 80238  
Plus d'informations  
More about this product  
Mehr zu diesem Produkt



REF: 56238  
Starter Kit

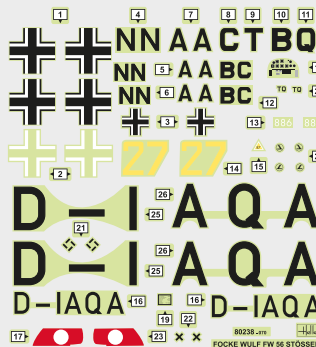

FW 56, TQ+BC, école de chasse 101, Zerbst, 1943

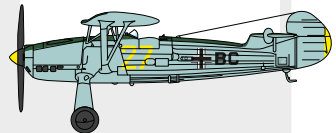

FW 56, NN+AA, école de pilotage, Borkheide, 1940



FW 56, D-IAQA, 1936



1977 2020

## BLOCH 174

**REF: 80312**  
Plus d'informations  
More about this product  
Mehr zu diesem Produkt



**REF: 56312**  
Starter Kit



**GR II/33 - 2ème Escadrille - TUNIS EL AOÛINA - Juin 1940**

**GR II/33 - 1ère Escadrille - TUNIS EL AOÛINA - 1941**

GR II/33 - 2ème Escadrille - Tunis el Aouina - Juin 1940

GR II/33 - 1ère Escadrille - Tunis el Aouina - 1941

1982 2020

## FOCKE-WULF FW 190 A5/A8/F8

**REF: 80235**  
Plus d'informations  
More about this product  
Mehr zu diesem Produkt



**REF: 56235**  
Starter Kit



Focke-Wulf Fw 190 A-8, Bad Aibling, 1945

Focke-Wulf Fw 190 F-8, I./SG 4, Piacenza, mai 1944

Focke-Wulf Fw 190 A-5/U12, Olt Erich Hondt, 2./JG 11, Husum, octobre 1943

1974 2022

**REF: 80312** **BLOCH 174** Scale: 1/72

<b>Année de fabrication</b> Year of construction • Baujahr	1939
<b>Quantité produite</b> Built quantity • Gebaute Menge	56
<b>Puissance</b> Power • Leistung	2 x 1140 CV/PS
<b>Vitesse maximale</b> Max. Speed • Max. Geschwindigkeit	530 km/h
<b>Envergure</b> Wing span • Flügelspannweite	17,92 m

168 x 253 mm 2 x Decorations provided 49 pieces

**REF: 80235** **FOCKE-WULF FW 190 A5/A8/F8** Scale: 1/72

<b>Année de fabrication</b> Year of construction • Baujahr	1943
<b>Quantité produite</b> Built quantity • Gebaute Menge	20.000 (all)
<b>Puissance</b> Power • Leistung	1730 CV / PS
<b>Vitesse maximale</b> Max. Speed • Max. Geschwindigkeit	657 km/h
<b>Envergure</b> Wing span • Flügelspannweite	10,51 m

147 x 124 mm 3 x Decorations provided 3 IN 1 61 pieces



REF: 80282 **SPITFIRE MK XVI E** Scale: 1/72

<b>Année de fabrication</b> Year of construction • Baujahr	1945
<b>Quantité produite</b> Built quantity • Gebaute Menge	20.351
<b>Puissance</b> Power • Leistung	1650 CV / PS
<b>Vitesse maximale</b> Max. Speed • Max. Geschwindigkeit	656 km/h
<b>Envergure</b> Wing span • Flügelspannweite	11,22 m

 133 x 138 mm 33 pieces

## SPITFIRE MK XVI E

**REF: 80282**  
Plus d'informations  
More about this product  
Mehr zu diesem Produkt



**REF: 56282**  
Starter Kit

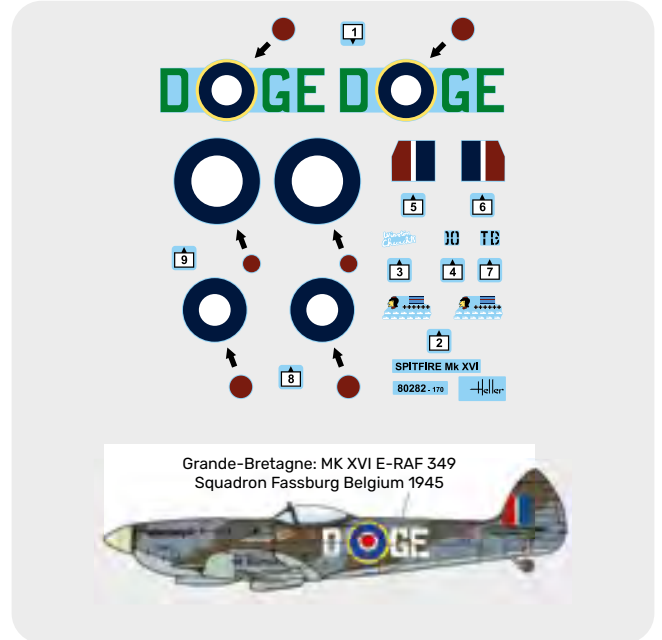

Grande-Bretagne: MK XVI E-RAF 349  
Squadron Fassburg Belgium 1945

1978 2022



REF: 80266 **P-40 KITTY HAWK** Scale: 1/72

<b>Année de fabrication</b> Year of construction • Baujahr	1942
<b>Quantité produite</b> Built quantity • Gebaute Menge	13.738
<b>Puissance</b> Power • Leistung	1217 CV/PS
<b>Vitesse maximale</b> Max. Speed • Max. Geschwindigkeit	560 km/h
<b>Envergure</b> Wing span • Flügelspannweite	11,40 m

 141 x 158 mm 3 x Decorations provided 43 pieces

## P-40 KITTY HAWK

**REF: 80266**  
Plus d'informations  
More about this product  
Mehr zu diesem Produkt



**REF: 56266**  
Starter Kit

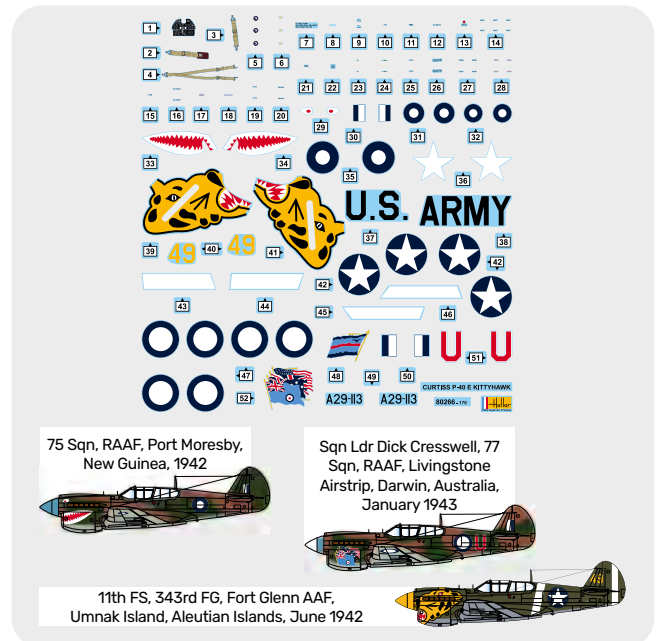

75 Sqn, RAAF, Port Moresby,  
New Guinea, 1942

Sqn Ldr Dick Cresswell, 77  
Sqn, RAAF, Livingstone  
Airstrip, Darwin, Australia,  
January 1943

11th FS, 343rd FG, Fort Glenn AAF,  
Umnak Island, Aleutian Islands, June 1942

1972 2023

## NORTH AMERICAN P-51 D MUSTANG

**REF: 80268**  
Plus d'informations  
More about this product  
Mehr zu diesem Produkt



**REF: 56268**  
Starter Kit

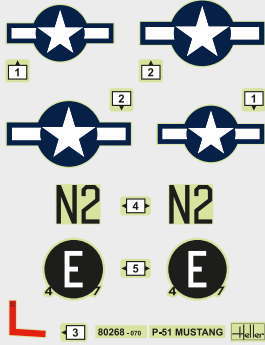

383rd FS, 364th FG,  
Honington,  
Grande-Bretagne/United Kingdom,  
1944

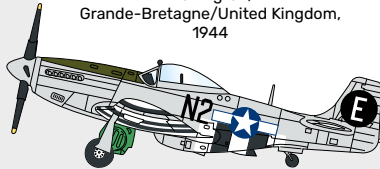

1973 2020

## PZL P-23 A/B KARAS

**REF: 80247**  
Plus d'informations  
More about this product  
Mehr zu diesem Produkt



**REF: 56247**  
Starter Kit



ROUMANIE: P-23 A  
Force Aérienne Roumaine  
1941-1942



POLOGNE, P-23 B 55<sup>ème</sup> Escadrille  
Brigade de Bombardement  
1939



1979 2021



REF: 80268

### NORTH AMERICAN P-51 D MUSTANG

Scale: 1/72

<b>Année de fabrication</b> Year of construction • Baujahr	1943
<b>Quantité produite</b> Built quantity • Gebaute Menge	8.200
<b>Puissance</b> Power • Leistung	1.490 CV/PS
<b>Vitesse maximale</b> Max. Speed • Max. Geschwindigkeit	708 km/h
<b>Envergure</b> Wing span • Flügelspannweite	11,28 m

137 x 156 mm

51 pieces



REF: 80247

### PZL P-23 A/B KARAS

Scale: 1/72

<b>Année de fabrication</b> Year of construction • Baujahr	1936
<b>Quantité produite</b> Built quantity • Gebaute Menge	250
<b>Puissance</b> Power • Leistung	570/590 CV/PS (P-23 A) / 660/680 CV/PS (P-23B)
<b>Vitesse maximale</b> Max. Speed • Max. Geschwindigkeit	310 km/h
<b>Envergure</b> Wing span • Flügelspannweite	13,95 m

134 x 194 mm

2 x Decorations provided  
2 IN 1

48 pieces



REF: 80229

**MESSERSCHMITT  
BF 109 K-4**

Scale: 1/72

<b>Année de fabrication</b> Year of construction • Baujahr	1944
<b>Quantité produite</b> Built quantity • Gebaute Menge	33.300 (all)
<b>Puissance</b> Power • Leistung	1800 CV / PS
<b>Vitesse maximale</b> Max. Speed • Max. Geschwindigkeit	728 km/h
<b>Envergure</b> Wing span • Flügelspannweite	9,92 m

138 x 126 mm    3 x Decorations provided    41 pieces

**MESSERSCHMITT BF 109 K-4**

**REF: 80229**  
Plus d'informations  
More about this product  
Mehr zu diesem Produkt



**REF: 56229**  
Starter Kit



1976 2022



REF: 80231

**MESSERSCHMITT  
BF 108-B TAIFUN**

Scale: 1/72

<b>Année de fabrication</b> Year of construction • Baujahr	1935
<b>Quantité produite</b> Built quantity • Gebaute Menge	885
<b>Puissance</b> Power • Leistung	240 CV/PS
<b>Vitesse maximale</b> Max. Speed • Max. Geschwindigkeit	305 km/h
<b>Envergure</b> Wing span • Flügelspannweite	10,50 m

115 x 146 mm    2 x Decorations provided    36 pieces

**MESSERSCHMITT  
BF 108-B TAIFUN**

**REF: 80231**  
Plus d'informations  
More about this product  
Mehr zu diesem Produkt



**REF: 56231**  
Starter Kit



1975 2020

## GRUMMAN F6F-5 HELLCAT

**REF: 80272**  
Plus d'informations  
More about this product  
Mehr zu diesem Produkt



**REF: 56272**  
Starter Kit



Flottille 1F, Aéronautique Navale, PA ARROMANCHES, Indochine, août 1951

VF-12, 9, Lt Hamilton McWhorter III, USS RANDOLPH (CV-15), janvier 1945

VF-12, 32, USS RANDOLPH (CV-15), Bataille d'Okinawa, avril 1945

MkII, 896 Sqn, Fleet Air Arm, HMS EMPEROR, Ceylan, juin 1945

1977 2020



REF: 80272 **GRUMMAN F6F-5 HELLCAT** Scale: 1/72

<b>Année de fabrication</b> Year of construction - Baujahr	1943
<b>Quantité produite</b> Built quantity - Gebaute Menge	8.555
<b>Puissance</b> Power - Leistung	2.000 CV/PS
<b>Vitesse maximale</b> Max. Speed - Max. Geschwindigkeit	629 km/h
<b>Envergure</b> Wing span - Flügelspannweite	13,04 m

142 x 181 mm 4 x Decorations provided 36 pieces

## DOUGLAS C-118 LIFTMASTER

**REF: 80317**  
Plus d'informations  
More about this product  
Mehr zu diesem Produkt



**REF: 56317**  
Starter Kit



0-33279 MAC U.S. AIR FORCE U.S. AIR FORCE 0-33279 MAC

MILITARY AIRLIFT COMMAND MILITARY AIRLIFT COMMAND

USAF, Military Airlift Command 1968

1984 2021



REF: 80317 **DOUGLAS C-118 LIFTMASTER** Scale: 1/72

<b>Année de fabrication</b> Year of construction - Baujahr	1946
<b>Quantité produite</b> Built quantity - Gebaute Menge	101
<b>Puissance</b> Power - Leistung	4 x 2.400 CV/PS
<b>Vitesse maximale</b> Max. Speed - Max. Geschwindigkeit	507 km/h
<b>Envergure</b> Wing span - Flügelspannweite	35,81 m

451 x 497 mm 92 pieces



REF: 80382 **LOCKHEED C-121A  
CONSTELLATION „MATS“** Scale: 1/72

<b>Année de fabrication</b> Year of construction • Baujahr	1947
<b>Quantité produite</b> Built quantity • Gebaute Menge	332
<b>Puissance</b> Power • Leistung	4 x 2.500 CV/PS
<b>Vitesse maximale</b> Max. Speed • Max. Geschwindigkeit	538 km/h
<b>Envergure</b> Wing span • Flügelspannweite	37,49 m

 403 x 521 mm 91 pieces

## LOCKHEED C-121A CONSTELLATION „MATS“

REF: 80382  
Plus d'informations  
More about this product  
Mehr zu diesem Produkt



REF: 56382  
Starter Kit

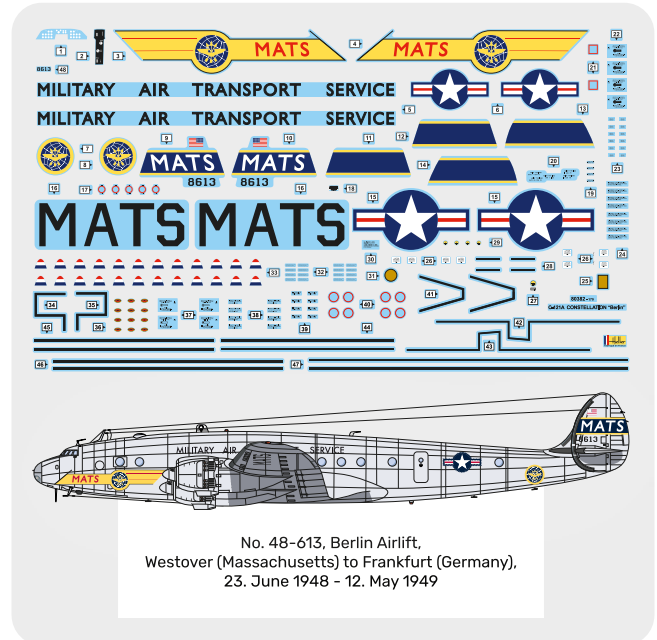

No. 48-613, Berlin Airlift,  
Westover (Massachusetts) to Frankfurt (Germany),  
23. June 1948 - 12. May 1949

1982 2020



REF: 30372 **C-47 DAKOTA** Scale: 1/72

<b>Année de fabrication</b> Year of construction • Baujahr	1945
<b>Quantité produite</b> Built quantity • Gebaute Menge	16.079
<b>Puissance</b> Power • Leistung	2x 1200 CV/PS
<b>Vitesse maximale</b> Max. Speed • Max. Geschwindigkeit	368 km/h
<b>Envergure</b> Wing span • Flügelspannweite	29,98 m

 273 x 400 mm 3 x Decorations provided 140 pieces

## C-47 DAKOTA

REF: 30372  
Plus d'informations  
More about this product  
Mehr zu diesem Produkt



REF: 35372  
Starter Kit



**NEW  
DECAL**





# LOCKHEED EC-121 WARNING STAR

**REF: 80311**  
Plus d'informations  
More about this product  
Mehr zu diesem Produkt



**REF: 56311**  
Starter Kit

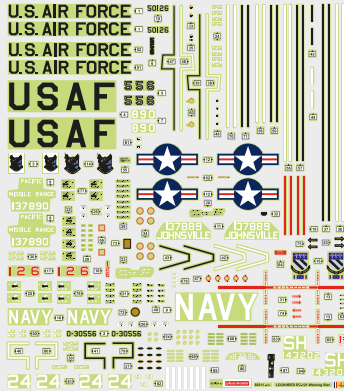

WV-2, No. Const. 4476, Immat. 143202, US Navy, Air Barrier Squadron 2, Barbers Point NAS, Hawaii, 1959

EC-121K, No. Const. 4347, Immat. 137890, US Navy, Pacific Missile Range, Mugu Point NAS, Californie, 1962

EC-121K, No. Const. 4346, Immat. 137889, US Navy, Naval Air Development Center (NADC), Johnsville NAS, Pennsylvanie, 1963

RC-121D, No. Const. 4399, Immat. 55-0126, US Air Force, 551 AEW & C Wing, Otis AFB, Massachusetts, 1962

EC-121Q, No. Const. 4371, Immat. 53-0556, US Air Force, 966 AEW & C Squadron, 552 AEW & C Wing, Keflavik Air Station, Islande, 1969



1983 2020

# F-86F SABRE / CANADAIR CL-13 B SABRE VI

**REF: 80277**  
Plus d'informations  
More about this product  
Mehr zu diesem Produkt



**REF: 56277**  
Starter Kit

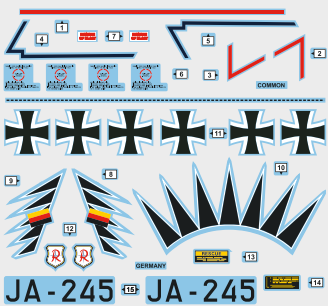

West Germany: 2.Staffel JG 71 Richthofen, JA-245, 1958



Royal Norwegian Air Force: A-FN 31151, 1961



1979 2020



REF: 80311 **LOCKHEED EC-121  
WARNING STAR** Scale: 1/72

<b>Année de fabrication</b> Year of construction - Baujahr	1954
<b>Quantité produite</b> Built quantity - Gebaute Menge	142
<b>Puissance</b> Power - Leistung	4 x 3.400 CV/PS
<b>Vitesse maximale</b> Max. Speed - Max. Geschwindigkeit	481 km/h
<b>Envergure</b> Wing span - Flügelspannweite	38,45 m
492 x 521 mm	5 x Decorations provided 105 pieces



REF: 80277 **F-86F SABRE /  
CANADAIR CL-13 B  
SABRE VI** Scale: 1/72

<b>Année de fabrication</b> Year of construction - Baujahr	1947
<b>Quantité produite</b> Built quantity - Gebaute Menge	3.194
<b>Puissance</b> Power - Leistung	26,3 kN
<b>Vitesse maximale</b> Max. Speed - Max. Geschwindigkeit	964 km/h - 1106 km/h
<b>Envergure</b> Wing span - Flügelspannweite	11,28 m
159 x 157 mm	2 x Decorations provided 58 pieces



REF: 80279 **T-28 FENNEC/TROJAN** Scale: 1/72

<b>Année de fabrication</b> Year of construction • Baujahr	1960 (USA) / 1949 (France)
<b>Quantité produite</b> Built quantity • Gebaute Menge	145 (USA) / 1948 (France)
<b>Puissance</b> Power • Leistung	1.425 CV/PS
<b>Vitesse maximale</b> Max. Speed • Max. Geschwindigkeit	550 km/h
<b>Envergure</b> Wing span • Flügelspannweite	12,21 m

 138 x 170 mm    5 x Decorations provided  
2 IN 1    45 pieces

## T-28 FENNEC/TROJAN

**REF: 80279**  
Plus d'informations  
More about this product  
Mehr zu diesem Produkt



**REF: 56279**  
Starter Kit



N°65 (s/n 51-7765), Force Aérienne Royale du Maroc

N°7 (s/n 51-7747), EALA 3/9, Bône (Algérie), 1961

N°57 (s/n 51-3491), EALA 3/5, Méchéria (Algérie), 1961

N°69 (s/n 51-3569), EALA 3/5, Méchéria (Algérie), 1961

137650, VT-5, US Navy, NAS Pensacola

1981 2020



REF: 80287 **SAAB 91 SAFIR** Scale: 1/72

<b>Année de fabrication</b> Year of construction • Baujahr	1945
<b>Quantité produite</b> Built quantity • Gebaute Menge	320
<b>Puissance</b> Power • Leistung	190 CV/PS
<b>Vitesse maximale</b> Max. Speed • Max. Geschwindigkeit	275 km/h
<b>Envergure</b> Wing span • Flügelspannweite	10,59 m

 110 x 147 mm    5 x Decorations provided  
22 pieces

## SAAB 91 SAFIR

**REF: 80287**  
Plus d'informations  
More about this product  
Mehr zu diesem Produkt



**REF: 56287**  
Starter Kit



SAAB 91 B «SAFIR», UA-T, N° Const. 91339, Immat. 57-339, Ecole de Pilotage, Armée de l'Air norvégienne, Værnes, 1972

SAAB 91 C «SAFIR», SF - 6, N° Const. 91352, Ecole de Pilotage (IlmaSK), Armée de l'Air finlandaise, Jyväskylä, 1970

SAAB 91 C - SK 50 C «SAFIR», 75, N° Const. 91408, Immat. 50093, Flygfliettiij 10, Armée de l'Air suédoise, Barkåkra, 1976

SAAB 91 D «SAFIR», 3F «SB», N° Const. 91453, Fliegerregiment 2 - 1 Staffel, Armée de l'Air autrichienne, Zeltweg, 1972

SAAB 91 D «SAFIR», SF - 29, N° Const. 91417, Ecole de Pilotage (IlmaSK), Armée de l'Air finlandaise, Jyväskylä, 1962

1981 2020

# Heller

1/72<sup>ème</sup> MVSÉE



**BLOCH 210**

REF: 80397 119 pièces

A. BLOCH MB 210 n°258 : 4e escadrille, GB II/23 (BR 129), Toulouse, 1938.  
 B. BLOCH MB 210 n°14 : 4e escadrille, GB II/21 (GB 9), La Ferté-Gaucher, mai 1940.





**BREGUET 693 AB<sup>2</sup>**

REF: 80392 57 pièces



**REF: 80397**  
 Plus d'informations  
 More about this product  
 Mehr zu diesem Produkt



**REF: 80392**  
 Plus d'informations  
 More about this product  
 Mehr zu diesem Produkt





**POTEZ 540**

REF: 80395 130 pièces

A. POTEZ 540 n°170 : Potez 540, F-AOOJ, Escadrille ministérielle, code A-OOJ, servant au transport du général de Gaulle, utilisé pour ses voyages à travers les possessions françaises en Afrique, 1941.  
 B. POTEZ 540 n°37 : (X-111), 1ère escadrille, GR I/55, Lyon-Bron, 1938.





**POTEZ 63-11**

REF: 80313 84 pièces

A. Potez 63-11 A3 n°156 du GR II/33, base à Athies-sous-Laon, 10 mai 1940.  
 B. Potez 63-11 A3 n°709 du GR I/36, fin 1942





**LIORÉ & OLIVER 45**

REF: 80398 90 pièces



**REF: 80395**  
 Plus d'informations  
 More about this product  
 Mehr zu diesem Produkt



**REF: 80313**  
 Plus d'informations  
 More about this product  
 Mehr zu diesem Produkt



**REF: 80398**  
 Plus d'informations  
 More about this product  
 Mehr zu diesem Produkt



Heller



REF: 80260

**TUNNAN**

Scale: 1/72

<b>Année de fabrication</b> Year of construction • Baujahr	1950
<b>Quantité produite</b> Built quantity • Gebaute Menge	661
<b>Puissance</b> Power • Leistung	22,26 kN
<b>Vitesse maximale</b> Max. Speed • Max. Geschwindigkeit	1.100 km/h
<b>Envergure</b> Wing span • Flügelspannweite	11 m

152 x 142 mm      2 x Decorations provided  
2 IN 1      40 pieces

**TUNNAN**

**REF: 80260**  
Plus d'informations  
More about this product  
Mehr zu diesem Produkt



**REF: 56260**  
Starter Kit

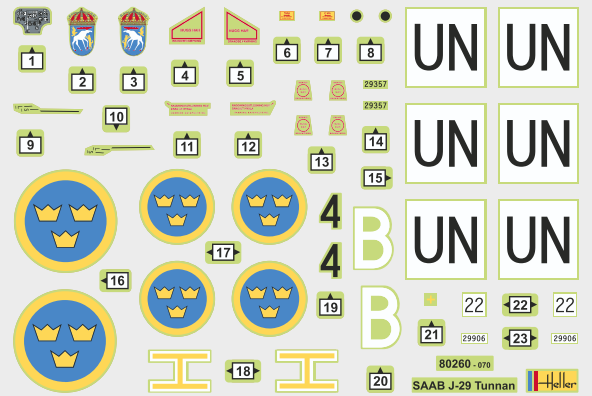

Sverige: J.29 E, F-4 Wing,  
Frösön, Östersund, 1956



Sverige / United Nations:  
S.29 C, F-4, Kamina, Congo,  
1962-1963



1977 2020

Heller



REF: 80220

**FOUGA MAGISTER CM 170**

Scale: 1/72

<b>Année de fabrication</b> Year of construction • Baujahr	1953
<b>Quantité produite</b> Built quantity • Gebaute Menge	1.009
<b>Puissance</b> Power • Leistung	480 kgp x 2
<b>Vitesse maximale</b> Max. Speed • Max. Geschwindigkeit	725 km/h
<b>Envergure</b> Wing span • Flügelspannweite	12,15 m

140 x 170 mm      2 x Decorations provided  
66 pieces

**FOUGA MAGISTER CM 170**

**REF: 80220**  
Plus d'informations  
More about this product  
Mehr zu diesem Produkt



**REF: 56220**  
Starter Kit

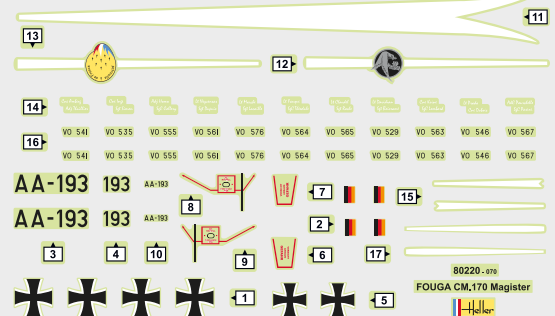

Patrouille de France,  
BA 701, Salon de Provence, 1978



Bundesluftwaffe,  
WS 50, 1966

1980 2020

## NORD 2501 + NORD 2502 NORATLAS

REF: 85374  
Plus d'informations  
More about this product  
Mehr zu diesem Produkt



REF: 55374  
Starter Kit

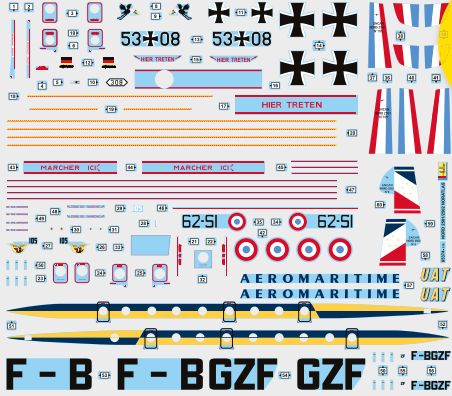

**TWIN SET**

Germany: No. 126, 53+08,  
Flugzeugführerschule (FFS-S),  
Luftwaffe, 1968

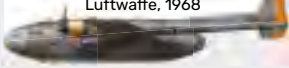

UAT - Aeromaritime, F-BGZF,  
Nord 2502, Jet drive



France: No. 105, 62-SI, GT 3/62  
„Sahara“, Armée de l'Air,  
BA 140 BLIDA, Algérie, 1961



1978 2020



REF: 85374 **NORD 2501 +  
NORD 2502 NORATLAS** Scale: 1/72

<b>Année de fabrication</b> Year of construction - Baujahr	1950
<b>Quantité produite</b> Built quantity - Gebaute Menge	426
<b>Puissance</b> Power - Leistung	2501: 2x 2.068 CV/PS 2502: + 2x3,92 kN
<b>Vitesse maximale</b> Max. Speed - Max. Geschwindigkeit	440 km/h
<b>Envergure</b> Wing span - Flügelspannweite	21,96 m

2 x 315 x 454 mm **TWIN SET** 2 x 117 pieces  
3 x Decorations provided

## JA-37 JAKTVIGGEN

REF: 80309  
Plus d'informations  
More about this product  
Mehr zu diesem Produkt



REF: 56309  
Starter Kit

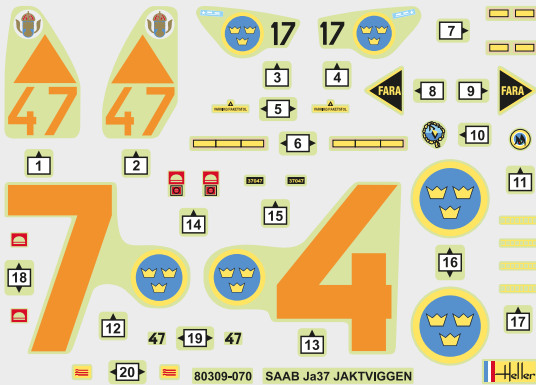

Sverige: 1 Jaktfggdivisionen,  
Ronnebg, 1992



1977 2020



REF: 80309 **JA-37  
JAKTVIGGEN** Scale: 1/72

<b>Année de fabrication</b> Year of construction - Baujahr	1967
<b>Quantité produite</b> Built quantity - Gebaute Menge	329
<b>Puissance</b> Power - Leistung	125,04 kN
<b>Vitesse maximale</b> Max. Speed - Max. Geschwindigkeit	2.200 km/h
<b>Envergure</b> Wing span - Flügelspannweite	10,60 m

229 x 147 mm 66 pieces



REF: 80343

**LANSEN**

Scale: 1/72

**Année de fabrication**

Year of construction • Baujahr 1955

**Quantité produite**

Built quantity • Gebaute Menge 456

**Puissance**

Power • Leistung 3.460 kp

**Vitesse maximale**

Max. Speed • Max. Geschwindigkeit 910 km/h

**Envergure**

Wing span • Flügelspannweite 13,00 m



203 x 179 mm

3 x Decorations provided  
2 IN 1

52 pieces

**LANSEN**

REF: 80343

Plus d'informations  
More about this product  
Mehr zu diesem Produkt



REF: 56343

Starter Kit



Sverige: A32A, Flygfötlitij 17,  
Ronneby, 1960



Sverige: A32A, Flygfötlitij 6,  
Karlsborg, 1965



Sverige: S32C, Flygfötlitij 11,  
Nyköping, 1960



1982 2020



REF: 80360

**SUPER ETENDARD**

Scale: 1/72

**Année de fabrication**

Year of construction • Baujahr 1978

**Quantité produite**

Built quantity • Gebaute Menge 85

**Puissance**

Power • Leistung 49,03 kN

**Vitesse maximale**

Max. Speed • Max. Geschwindigkeit 1200 km/h

**Envergure**

Wing span • Flügelspannweite 9,60 m



198 x 133 mm

43 pieces

**SUPER ETENDARD**

REF: 80360

Plus d'informations  
More about this product  
Mehr zu diesem Produkt



REF: 56360

Starter Kit



FRANCE: SUPER ETENDARD 11 F,  
1983

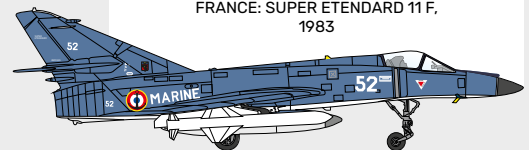

1984 2023

## E-3B AWACS

REF: 80308

Plus d'informations  
More about this product  
Mehr zu diesem Produkt



REF: 56308

Starter Kit



Pnr22855,  
LX-N90442, NAEW  
& CF,  
50th Anniversary  
Livery,  
Geilenkirchen NATO  
Air Base, Germany,  
1999

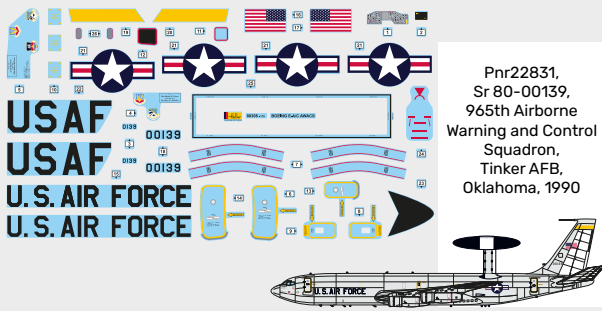

Pnr22831,  
Sr 80-00139,  
965th Airborne  
Warning and Control  
Squadron,  
Tinker AFB,  
Oklahoma, 1990

1987 2021



REF: 80308

**E-3B AWACS**

Scale: 1/72

**Année de fabrication**

Year of construction • Baujahr

1977

**Quantité produite**

Built quantity • Gebaute Menge

68

**Puissance**

Power • Leistung

372 kW

**Vitesse maximale**

Max. Speed • Max. Geschwindigkeit

858 km/h

**Envergure**

Wing span • Flügelspannweite

44,45 m

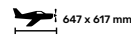

647 x 617 mm

2 x Decorations provided

108 pieces

## MIRAGE F1 B

REF: 30319

Plus d'informations  
More about this product  
Mehr zu diesem Produkt



REF: 35319

Starter Kit

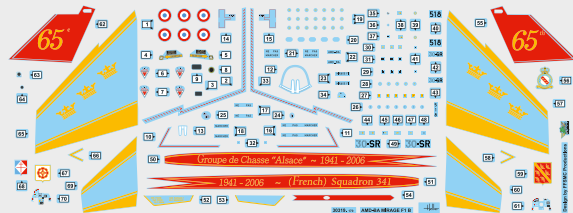

N°518, 30-SR, EC (escadron de chasse) 1/30 Alsace,  
décoration spéciale pour les 65 ans de l'escadron, BA (Base  
aérienne) 132 de Colmar-Meyenheim, Juin 2006



N°518, 30-SR, EC 1/30 Alsace,  
BA 132 de Colmar-Meyenheim, 2006



REF: 30319

**MIRAGE F1 B**

Scale: 1/72

**Année de fabrication**

Year of construction • Baujahr

1976

**Quantité produite**

Built quantity • Gebaute Menge

57

**Puissance**

Power • Leistung

49,03 kW /  
70,61 kW with PC

**Vitesse maximale**

Max. Speed • Max. Geschwindigkeit

Mach 2.2 / 2335 km/h

**Envergure**

Wing span • Flügelspannweite

8,40 m

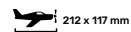

212 x 117 mm

2 x Decorations provided

79 pieces



REF: 80323

**MIRAGE III  
E/R/5**

Scale: 1/72

<b>Année de fabrication</b> Year of construction • Baujahr	1963
<b>Quantité produite</b> Built quantity • Gebaute Menge	418
<b>Puissance</b> Power • Leistung	6.400 kgp
<b>Vitesse maximale</b> Max. Speed • Max. Geschwindigkeit	2.350 km/h
<b>Envergure</b> Wing span • Flügelspannweite	8,22 m

217 x 144 mm      3 x Decorations provided  
3 IN 1      54 pieces

**MIRAGE III E/R/5**

**REF: 80323**  
Plus d'informations  
More about this product  
Mehr zu diesem Produkt



**REF: 56323**  
Starter Kit



Espagne: Mirage III C-11, 101-03, Esc 101, Manises

Belgique: Mirage 5 N° 08, BA 08

France: Mirage III R N°321, 33-NM, ER 2/33 „Savoie“

1976 2020



REF: 80303

**MIRAGE 2000 C**

Scale: 1/72

<b>Année de fabrication</b> Year of construction • Baujahr	1986
<b>Quantité produite</b> Built quantity • Gebaute Menge	136
<b>Puissance</b> Power • Leistung	64,3 kN / 95,1 kN with afterburner
<b>Vitesse maximale</b> Max. Speed • Max. Geschwindigkeit	Mach 2.3 / 2336 km/h
<b>Envergure</b> Wing span • Flügelspannweite	9,13 m

203 x 127 mm      2 x Decorations provided  
39 pieces

**MIRAGE 2000 C**

**REF: 80303**  
Plus d'informations  
More about this product  
Mehr zu diesem Produkt



**REF: 56303**  
Starter Kit



FRANCE: N°23, 2-LH, E.C. 3/2 "Alsace", 2ème Escadre, DIJON, 1991

EGYPTE: N°102, Egyptian Air Force, 1986

1979 2023



## DASSAULT MIRAGE 2000 N

REF: 80321  
Plus d'informations  
More about this product  
Mehr zu diesem Produkt



REF: 56321  
Starter Kit

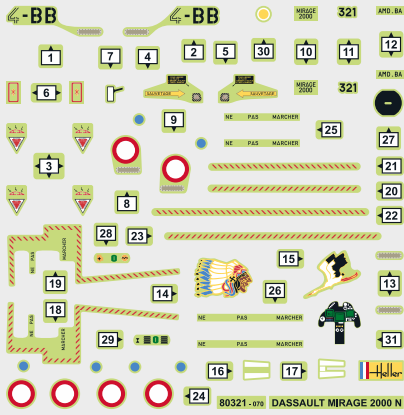

France : Mirage 2000N ,  
2/4 Lafayette, 1989

1989 2020



Heller



REF: 80321

### DASSAULT MIRAGE 2000 N

Scale: 1/72

<b>Année de fabrication</b> Year of construction - Baujahr	1983
<b>Quantité produite</b> Built quantity - Gebaute Menge	75
<b>Puissance</b> Power - Leistung	6486 kwp
<b>Vitesse maximale</b> Max. Speed - Max. Geschwindigkeit	2340 km/h
<b>Envergure</b> Wing span - Flügelspannweite	9,13 m
 208 x 127 mm	48 pieces

## TRANSALL C-160 „RETRO BRUMMEL“

REF: 80358  
Plus d'informations  
More about this product  
Mehr zu diesem Produkt



REF: 56358  
Starter Kit

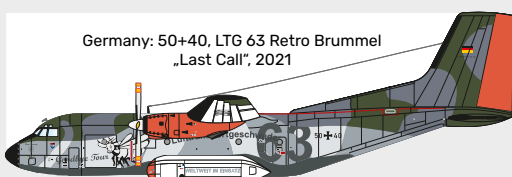
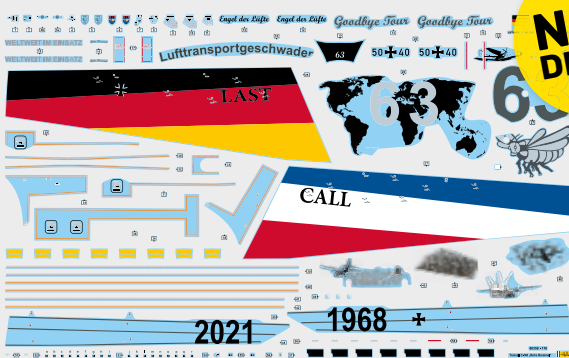

Germany: 50+40, LTG 63 Retro Brummel  
„Last Call“, 2021

1984 2022

Heller



REF: 80358

### TRANSALL C-160 „RETRO BRUMMEL“

Scale: 1/72

<b>Année de fabrication</b> Year of construction - Baujahr	1967
<b>Quantité produite</b> Built quantity - Gebaute Menge	214
<b>Puissance</b> Power - Leistung	2x 5.738 CV / PS
<b>Vitesse maximale</b> Max. Speed - Max. Geschwindigkeit	513 km/h
<b>Envergure</b> Wing span - Flügelspannweite	40 m
 451 x 555 mm	57 pieces



REF: 80371 **SU-27 UB/P UKRAINE 2009 - 2022** Scale: 1/72

<b>Année de fabrication</b> Year of construction · Baujahr	1991
<b>Quantité produite</b> Built quantity · Gebaute Menge	680
<b>Puissance</b> Power · Leistung	2 x 122,58 kN
<b>Vitesse maximale</b> Max. Speed · Max. Geschwindigkeit	Mach 2,35
<b>Envergure</b> Wing span · Flügelspannweite	14,70 m

 314 x 204 mm      2 x Decorations provided 2 IN 1      93 pieces

**SU-27 UB/P UKRAINE 2009 - 2022**

REF: 80371  
Plus d'informations  
More about this product  
Mehr zu diesem Produkt



REF: 56371  
Starter Kit



**NEW  
DECAL**



1990 2023

**PREVIEW**

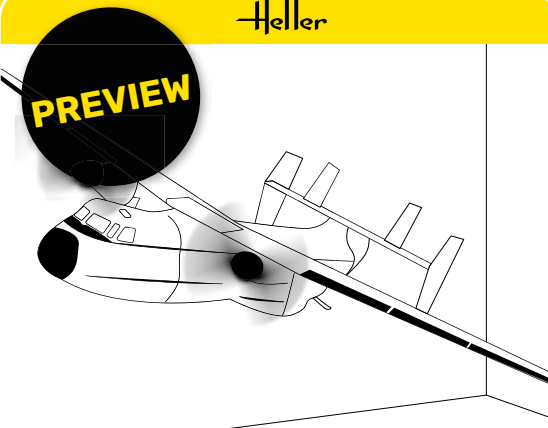

REF: 82303 **C-2 GREYHOUND** Scale: 1/72

<b>Année de fabrication</b> Year of construction · Baujahr	1965/1989
<b>Quantité produite</b> Built quantity · Gebaute Menge	58
<b>Puissance</b> Power · Leistung	2x 4620 CV / PS
<b>Vitesse maximale</b> Max. Speed · Max. Geschwindigkeit	533 km/h
<b>Envergure</b> Wing span · Flügelspannweite	24,50 m

 240 x 340 mm

**C-2 GREYHOUND**

REF: 82303  
Plus d'informations  
More about this product  
Mehr zu diesem Produkt



REF: 56303  
Starter Kit



**NEW  
DECAL &  
TOOL**



2023

## SUPER PUMA AS 332 M1

**REF: 80367**  
Plus d'informations  
More about this product  
Mehr zu diesem Produkt



**REF: 56367**  
Starter Kit



**A - Super Puma AS332 M1 - 4e RHCM - PHALSBOURG - 1990**

**B - Super Puma AS332 M1 - FLIEGERREGIMENT - LtSt 5 - 1990**

France: 4e RHCM - PHALSBOURG - 1990

Swiss: FLIEGERREGIMENT - LtSt 5 - 1990

1991 2020

## UH-72A LAKOTA

**REF: 80379**  
Plus d'informations  
More about this product  
Mehr zu diesem Produkt



**REF: 56379**  
Starter Kit



**NEW DECAL**

2006 2023

**REF: 80367** **SUPER PUMA AS 332 M1** Scale: 1/72

<b>Année de fabrication</b> Year of construction - Baujahr	1978
<b>Puissance</b> Power - Leistung	2 x 1611,15 CV/PS
<b>Vitesse maximale</b> Max. Speed - Max. Geschwindigkeit	278 km/h
<b>Envergure</b> Wing span - Flügelspannweite	Ø 15,60 m

260 x 217 mm 2 x Decorations provided 78 pieces

**PREVIEW**

**REF: 80379** **UH-72A LAKOTA** Scale: 1/72

<b>Année de fabrication</b> Year of construction - Baujahr	2006
<b>Puissance</b> Power - Leistung	2x 747 CV/PS
<b>Vitesse maximale</b> Max. Speed - Max. Geschwindigkeit	268 km/h
<b>Envergure</b> Wing span - Flügelspannweite	Ø 11 m

181 x 153 mm 110 pieces



25x FIGURINES

Heller

REF: 30313 **A.S. 51 HORSA + BRITISH PARATROOPERS** Scale: 1/72

<b>Année de fabrication</b> Year of construction · Baujahr	1941
<b>Quantité produite</b> Built quantity · Gebaute Menge	3.700
<b>Puissance</b> Power · Leistung	/
<b>Vitesse maximale</b> Max. Speed · Max. Geschwindigkeit	160km/h
<b>Envergure</b> Wing span · Flügelspannweite	26,8m

284 x 360 mm    25x | 25 mm    130 pieces

## A.S. 51 HORSA + BRITISH PARATROOPERS

REF: 30313  
Plus d'informations  
More about this product  
Mehr zu diesem Produkt



REF: 35313  
Starter Kit

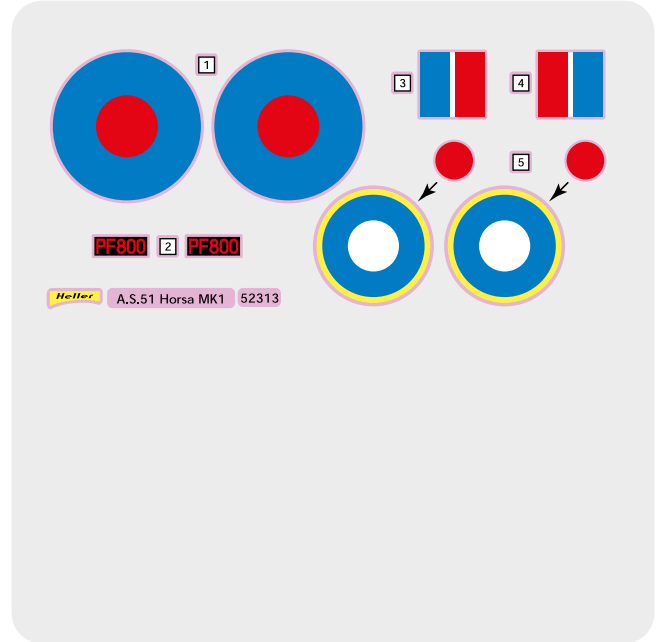

## NORMANDY AIRWAR

REF: 50329  
Plus d'informations  
More about this product  
Mehr zu diesem Produkt



REF: 52329  
Starter Kit



46x FIGURINES

Heller

REF: 50329 **NORMANDY AIRWAR** Scale: 1/72

	Focke Wulf Fw190 A8	P-51D Mustang
<b>Année de fabrication</b> Year of construction · Baujahr	1943	1943
<b>Quantité produite</b> Built quantity · Gebaute Menge	20.000 (all)	8.200
<b>Puissance</b> Power · Leistung	1730 CV/PS	1490 CV/PS
<b>Vitesse maximale</b> Max. Speed · Max. Geschwindigkeit	657 km/h	708 km/h
<b>Envergure</b> Wing span · Flügelspannweite	10,51 m	11,28 m

2x 147 x 124 mm / 137 x 156 mm    46x | 25 mm    158 pieces

6 x Decorations provided

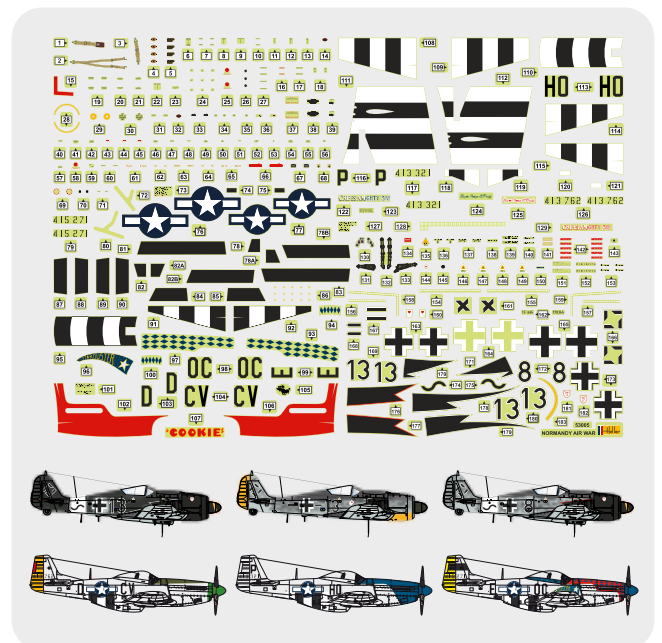

## A-10 THUNDERBOLT II

REF: 79912  
Plus d'informations  
More about this product  
Mehr zu diesem Produkt



REF: 56912  
Starter Kit

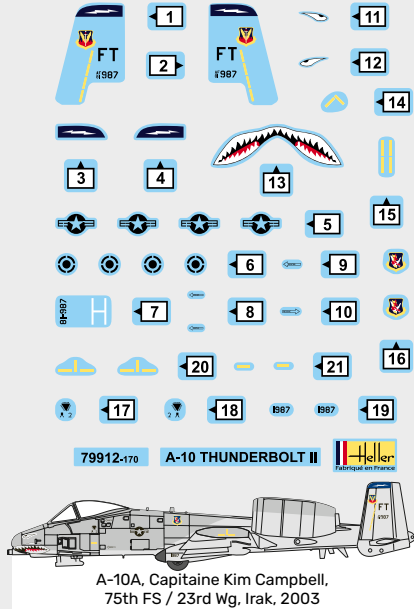

2004 2022



REF: 79912 **A-10 THUNDERBOLT II** Scale: 1/144

<b>Année de fabrication</b> Year of construction - Baujahr	1983
<b>Quantité produite</b> Built quantity - Gebaute Menge	716
<b>Puissance</b> Power - Leistung	2x 40,32 kN
<b>Vitesse maximale</b> Max. Speed - Max. Geschwindigkeit	706 km/h
<b>Envergure</b> Wing span - Flügelspannweite	17,53 m

112 x 121 mm 51 pieces

ADVERTISEMENT

REF: 80150  
RENAULT R5 TURBO

Scale: 1/43	30 Pieces
84 x 41 mm	



Distributed by  
**GLOW2B**  
germany

**TURBO LEGEND**  
Homage to the boldest three and  
and a half metres in the world



REF: 80717  
RENAULT R5 TURBO

Scale: 1/24	39 Pieces
161 x 70 mm	



SMIT ROTTERDAM



Heller

# MARINE CIVILE

CIVIL SHIPPING  
ZIVILE SCHIFFFAHRT

# AVENIR

**[FRANÇAIS]** Dès les années 1960, le modèle du car-ferry commence à se répandre en Méditerranée. Début 1965, la Compagnie de Navigation Mixte basée à Marseille passe commande au Forges et Chantiers de la Méditerranée, à la Seyne-sur-Mer, d'un paquebot car-ferry. L'AVENIR sera son premier car-ferry et le dernier navire commandé par la compagnie. Mis sur cale le 4 novembre 1965, l'AVENIR est lancé le 21 juin 1966 et livré à la „Mixte“ le 25 mars 1967 (IMO- International Maritime Organization-6614815). Reprenons les termes de sa présentation officielle en 1967: „Conçu aujourd'hui pour le tourisme de demain, l'Avenir est un authentique paquebot de luxe avec tous les raffinements du confort.“

**[ENGLISH]** From the 1960s onwards, car ferries became widespread in the Mediterranean. In early 1965, the Marseille-based Compagnie de Navigation Mixte ordered a car ferry from Forges et Chantiers de la Méditerranée in La Seyne-sur-Mer. The Avenir was their first car ferry and the last vessel ordered

by the company. Commissioned on 4 November 1965, the Avenir was launched on 21 June 1966 and delivered to the „Mixte“ on 25 March 1967 (IMO-International Maritime Organisation-6614815). An excerpt from the official launch in 1967: “Designed today for the tourism of tomorrow, the Avenir is a true luxury ferry with the highest level of comfort.”

**[DEUTSCH]** Seit den 1960er Jahren verbreiteten sich Autofähren im Mittelmeerraum. Anfang 1965 gab die Compagnie de Navigation Mixte mit Sitz in Marseille bei Forges et Chantiers de la Méditerranée in La Seyne-sur-Mer eine Autofähre in Auftrag. Die Avenir war ihre erste Autofähre und das letzte Schiff, das das Unternehmen bestellt hatte. Die am 4. November 1965 in Auftrag gegebene Avenir lief am 21. Juni 1966 vom Stapel und wurde am 25. März 1967 an die „Mixte“ ausgeliefert (IMO-International Maritime Organisation 6614815). Ein Auszug aus der offiziellen Vorstellung im Jahr 1967: „Die Avenir wurde heute für den Tourismus von morgen konzipiert und ist eine echte Luxusfähre mit höchstem Komfort.“



REF: 80625 **AVENIR** Scale: 1/200

<b>Année de fabrication</b> Year of construction • Baujahr	1966	
<b>Quantité produite</b> Built quantity • Gebaute Menge	1	
<b>Puissance</b> Power • Leistung	15.000 CV / PS	
<b>Vitesse maximale</b> Max. Speed • Max. Geschwindigkeit	21.5 knots	
<b>Longueur totale</b> Total length • Gesamtlänge	130 m	
 650 x 91 mm	3 x Decorations provided	622 pieces



**REF: 80625**  
Plus d'informations  
More about this product  
Mehr zu diesem Produkt



**REF: 56625**  
Starter Kit







FRANCE:  
Avenir,  
1965

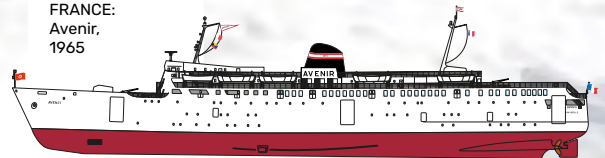

ITALIA:  
Espresso Corinto,  
1976



EMIRATES:  
Shahrazad,  
1984

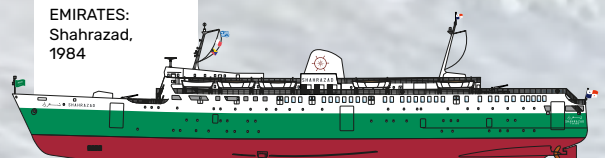



**VOLONTAIRE  
+  
MARIE JEANNE**

REF: 85604

Scale: 1/200

<b>Année de fabrication</b> Year of construction • Baujahr	1950
<b>Quantité produite</b> Built quantity • Gebaute Menge	1
<b>Puissance</b> Power • Leistung	1100 CV/PS
<b>Vitesse maximale</b> Max. Speed • Max. Geschwindigkeit	12 Knots
<b>Longueur totale</b> Total length • Gesamtlänge	68,50 m
2 x  340 x 58 mm	TWIN SET 2 x Decorations provided
	2 x 84 pieces

**VOLONTAIRE + MARIE JEANNE**

REF: 85604  
Plus d'informations  
More about this product  
Mehr zu diesem Produkt



REF: 55604  
Starter Kit



**TWIN SET**

- 1 SM.767 VOLONTAIRE
- 2 VOLONTAIRE SM.767
- VOLONTAIRE S' MALO SM.767
- 3
- 4
- MARIE-JEANNE CONCARNEAU
- 5
- 6
- 7 85604-070 VOLONTAIRE / MARIE-JEANNE
- 8
- 9 CC.768
- 10
- CC.768 MARIE-JEANNE
- MARIE-JEANNE CC.768



1967 2020



**JEAN BART  
+  
UTRECHT**

REF: 85602

Scale: 1/200

<b>Année de fabrication</b> Year of construction • Baujahr	1956
<b>Quantité produite</b> Built quantity • Gebaute Menge	1
<b>Puissance</b> Power • Leistung	2 x 1.250 CV/PS
<b>Vitesse maximale</b> Max. Speed • Max. Geschwindigkeit	17 Knots
<b>Longueur totale</b> Total length • Gesamtlänge	52,60 m
2 x  261 x 51 mm	TWIN SET 2 x Decorations provided
	2 x 123 pieces

**JEAN BART + UTRECHT**

REF: 85602  
Plus d'informations  
More about this product  
Mehr zu diesem Produkt



REF: 55602  
Starter Kit



**TWIN SET**

- 1
- 27 27
- 2
- 3
- 4
- 5
- 6
- 7
- 8
- 9
- 10
- 11
- 12
- 13
- 14
- 15
- 16
- 17
- 18
- 19
- 20



1976 2020

## ROC AMADOUR + BOÛASTEINUR

REF: 85608  
Plus d'informations  
More about this product  
Mehr zu diesem Produkt



REF: 55608  
Starter Kit



**TWIN SET**

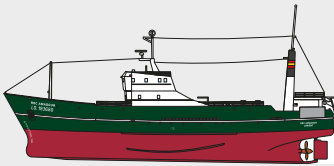
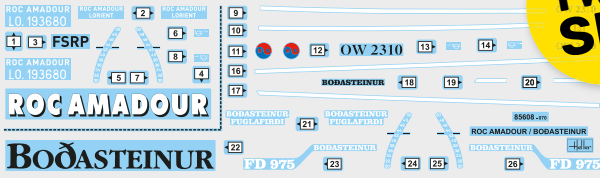

ROC AMADOUR, Armement Avry Frères, Lorient, 1974

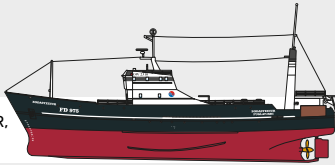

BOÛASTEINUR, P/F BOÛASTEINUR, Fuglafjørður, 1995

1977 2020

## SMIT ROTTERDAM SMIT LONDON

REF: 80620  
Plus d'informations  
More about this product  
Mehr zu diesem Produkt



REF: 56620  
Starter Kit



SMIT ROTTERDAM

1

SMIT ROTTERDAM

2



SMIT ROTTERDAM  
ROTTERDAM

SMIT LONDON  
ROTTERDAM

4

SMIT ROTTERDAM  
ROTTERDAM

SMIT LONDON  
ROTTERDAM

3

SMIT LONDON

5

SMIT LONDON

80620 - 170

SMIT ROTTERDAM



Smit London

Smit Rotterdam

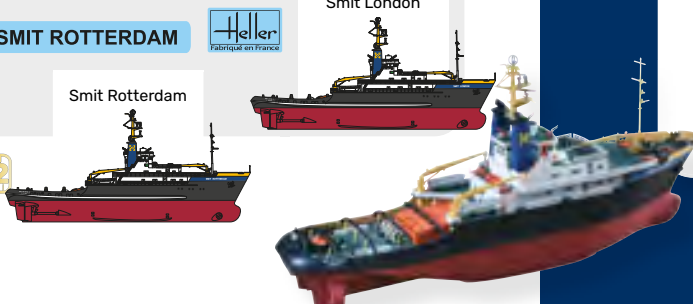

1977 2022



### ROC AMADOUR + BOÛASTEINUR

REF: 85608

Scale: 1/200

<b>Année de fabrication</b> Year of construction - Baujahr	1973
<b>Quantité produite</b> Built quantity - Gebaute Menge	1
<b>Puissance</b> Power - Leistung	2.398 CV/PS
<b>Vitesse maximale</b> Max. Speed - Max. Geschwindigkeit	9-11 Knots
<b>Longueur totale</b> Total length - Gesamtlänge	52,99 m
2 x  265 x 54 mm	TWIN SET 2 x Decorations provided
	2 x 160 pieces



### SMIT ROTTERDAM SMIT LONDON

REF: 80620

Scale: 1/200

<b>Année de fabrication</b> Year of construction - Baujahr	1975
<b>Quantité produite</b> Built quantity - Gebaute Menge	2
<b>Puissance</b> Power - Leistung	22.000 CV/PS
<b>Vitesse maximale</b> Max. Speed - Max. Geschwindigkeit	15,5 kn
<b>Portée en jours</b> Range in days - Reichweite in Tagen	20 days in transit
376 x 75 mm	2 x Decorations provided
	101 pieces

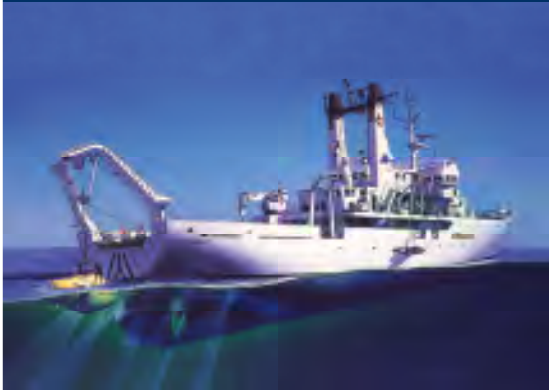

**TITANIC SEARCHER LE SUROIT**  
 REF: 80615 Scale: 1/200

<b>Année de fabrication</b> Year of construction • Baujahr	1975
<b>Quantité produite</b> Built quantity • Gebaute Menge	1
<b>Puissance</b> Power • Leistung	2 x 825 CV/PS
<b>Vitesse maximale</b> Max. Speed • Max. Geschwindigkeit	6,8 Knots / 13.3 Knots / 11 Knots in transit
<b>Portée en jours</b> Range in days • Reichweite in Tagen	21 days in transit
282 x 55 mm	110 pieces

**TITANIC SEARCHER LE SUROIT**

REF: 80615  
 Plus d'informations  
 More about this product  
 Mehr zu diesem Produkt



REF: 56615  
 Starter Kit

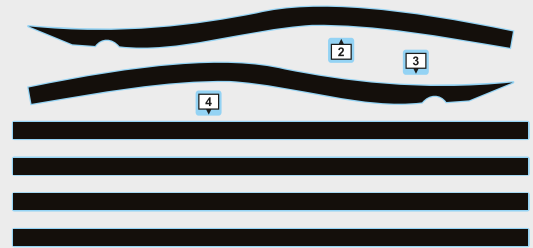

1980 2020



**QUEEN MARY 2**  
 REF: 80626 Scale: 1/600

<b>Année de fabrication</b> Year of construction • Baujahr	2000 / 2003
<b>Vitesse maximale</b> Max. Speed • Max. Geschwindigkeit	29,35 kn (~ 55 km/h)
<b>Longueur totale</b> Total length • Gesamtlänge	345 m
575 x 75 mm	239 pieces

**QUEEN MARY 2**

REF: 80626  
 Plus d'informations  
 More about this product  
 Mehr zu diesem Produkt



REF: 56626  
 Starter Kit

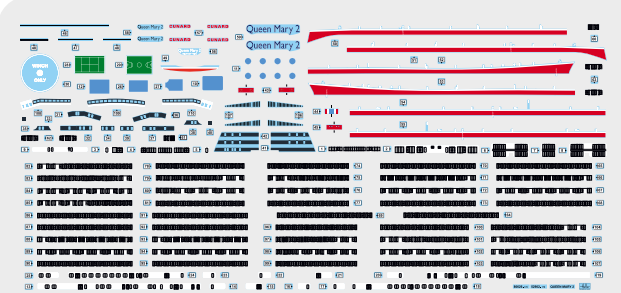

2004 2020



## LET'S GO BIG!

Over 1.500 parts, high quality accessories including aluminium-gun barrel, side skirts and photo etched parts



REF: 30321

## Pz.Kpfw. III Ausf. J | L | M (4IN1)

Scale: 1/16    1500+ Pieces



420 x 205 mm  
343 x 188 mm

4 x Versions provided

### Specials:

- Aluminium cannon for type J
- Photo-Etched parts
- Side skirts
- Movable single link tracks
- Copper cables 2x



- BISMARCK -  
- BREVILLES ANTIARRIE 14 F -

*Paulin ylli*



Heller

# MARINE MILITAIRE

MILITARY SHIPPING  
MILITÄRISCHE SCHIFFFAHRT

# CHARLES DE GAULLE 2001

**[FRANÇAIS]** L'histoire du Charles de Gaulle commence en 1974, année où la crise pétrolière ébranle les pays industrialisés. Dans ce contexte, le gouvernement français décide de lancer la construction du Porte-Hélicoptères-75, un porte-hélicoptères de 16 400 t doté de chaufferies nucléaires, projet qui sera finalement abandonné. En 1982, le Conseil Supérieur de la Marine demande que les études réalisées pour la propulsion nucléaire du projet PH-75 (devenu entretemps Porte-Avions-75 puis PA-83) soient utilisées pour définir une nouvelle génération de porte-avions capables de remplacer le Clémenceau et le Foch avant la fin du siècle.

**[ENGLISH]** The story of the Charles de Gaulle began in 1974, when the oil crisis shook the industrialised countries. In this context, the French government decided to launch the construction of the Porte-Hélicoptères-75, a 16,400-ton helicopter carrier equipped with nuclear boilers, a project that was eventually abandoned. In 1982, the French Navy High Council requested that the studies carried out for the nuclear propulsion of the PH-75 project (which in the meantime had become Aircraft Carrier-75 and then PA-83) be used to define a new generation of aircraft carriers capable of replacing the Clemenceau and Foch before the end of the century.

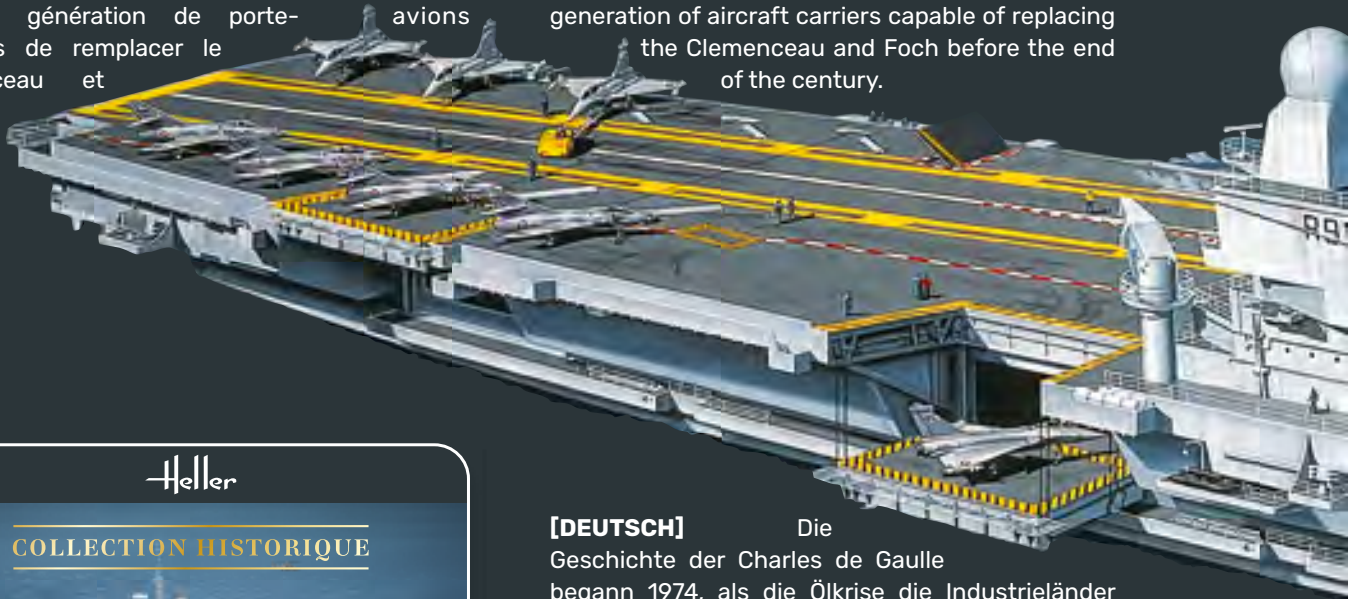

**COLLECTION HISTORIQUE**

**CHARLES DE GAULLE 2001**      Scale: 1/400

REF: 81072

<b>Année de fabrication</b> Year of construction · Baujahr	1989 / 1994
<b>Quantité produite</b> Built quantity · Gebaute Menge	1
<b>Puissance</b> Power · Leistung	83.000 CV/PS
<b>Vitesse maximale</b> Max. Speed · Max. Geschwindigkeit	27 kn
<b>Longueur totale</b> Total length · Gesamtlänge	261,50 m

654 x 161 mm      140 pieces

**[DEUTSCH]** Die Geschichte der Charles de Gaulle begann 1974, als die Ölkrise die Industrieländer erschütterte. In diesem Zusammenhang beschloss die französische Regierung, den Bau des Porte-Hélicoptères-75, eines 16.400 Tonnen schweren Hubschrauberträgers mit Atomtrieb, in Angriff zu nehmen, ein Projekt, das schließlich aufgegeben wurde. 1982 beantragte der Hohe Rat der französischen Marine, dass die Studien für den Nuklearantrieb des PH-75-Projekts (aus dem in der Zwischenzeit Flugzeugträger-75 und dann PA-83 geworden war) zur Definition einer neuen Generation von Flugzeugträgern verwendet werden sollten, die die Clemenceau und Foch noch vor Ende des Jahrhunderts ersetzen könnten.



**REF: 81072**  
Plus d'informations  
More about this product  
Mehr zu diesem Produkt



**REF: 57072**  
Starter Kit







BECHENNEC &

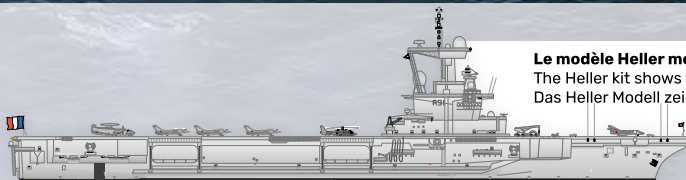

**Le modèle Heller montre la version du Charles de Gaulle de 2001 (première version)**  
The Heller kit shows the Charles de Gaulle of 2001 (early version)  
Das Heller Modell zeigt die Ausführung der Charles de Gaulle von 2001 (frühe Ausführung)

Heller

COLLECTION HISTORIQUE



**BISMARCK + TIRPITZ**

REF: 85078 Scale: 1/400

<b>Année de fabrication</b> Year of construction • Baujahr	1940 / 1941
<b>Quantité produite</b> Built quantity • Gebaute Menge	1
<b>Puissance</b> Power • Leistung	150 000 CV / PS 163 000 CV / PS
<b>Vitesse maximale</b> Max. Speed • Max. Geschwindigkeit	30,5 knots / 30,8 knots
<b>Longueur totale</b> Total length • Gesamtlänge	251 m

2 x  620 x 90 mm TWIN SET 327 + 337 pieces  
2 x Decorations provided

**BISMARCK + TIRPITZ**

REF: 85078  
Plus d'informations  
More about this product  
Mehr zu diesem Produkt



REF: 55078  
Starter Kit





Bismarck „Rheinübung“,  
May 1941



Tirpitz „Rösselsprung“,  
July 1942

1974 2021

Heller

COLLECTION HISTORIQUE

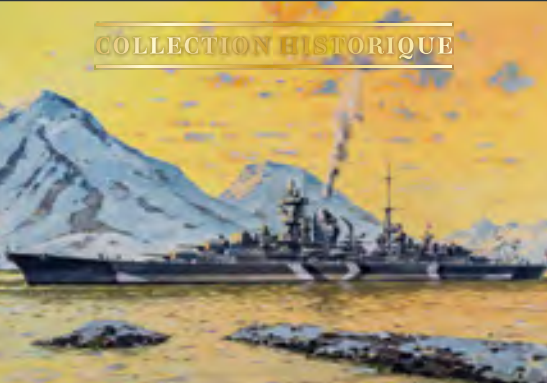

**PRINZ EUGEN + ADMIRAL HIPPER**

REF: 85083 Scale: 1/400

<b>Année de fabrication</b> Year of construction • Baujahr	1940 / 1939
<b>Quantité produite</b> Built quantity • Gebaute Menge	1
<b>Puissance</b> Power • Leistung	95000 CV / PS 80000 CV / PS
<b>Vitesse maximale</b> Max. Speed • Max. Geschwindigkeit	32 knots
<b>Longueur totale</b> Total length • Gesamtlänge	212 m

2 x  515 x 55 mm TWIN SET 299 + 261 pieces  
2 x Decorations provided

**PRINZ EUGEN + ADMIRAL HIPPER**

REF: 85083  
Plus d'informations  
More about this product  
Mehr zu diesem Produkt



REF: 55083  
Starter Kit





Prinz Eugen  
„Rheinübung“,  
May 1941



Admiral Hipper  
„Rösselsprung“,  
July 1942

1976 2021

## TORPEDOBOOT T23

REF: 81011  
Plus d'informations  
More about this product  
Mehr zu diesem Produkt



REF: 57011  
Starter Kit



T 0123456789  
T 0123456789

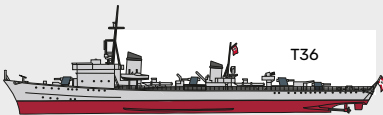
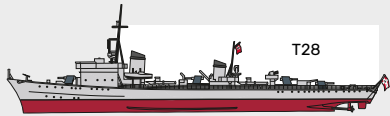
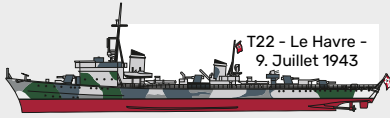
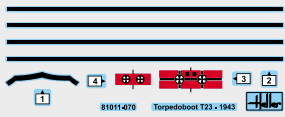

1980 2020

## U-BOOT TYPE VII C

REF: 81002  
Plus d'informations  
More about this product  
Mehr zu diesem Produkt



REF: 57002  
Starter Kit



- |                           |                           |                            |                            |
|---------------------------|---------------------------|----------------------------|----------------------------|
| <b>U-BOOT Typ VII C</b>   | <b>U-67</b>               | <b>U-772</b>               | <b>U-BOOT Typ VII C 41</b> |
| <b>U-79</b>               | 5. Unterseebootsflottille | 10. Unterseebootsflottille | <b>U-294</b>               |
| 1. Unterseebootsflottille | <b>U-179</b>              | <b>U-251</b>               | 14. Unterseebootsflottille |
| <b>U-128</b>              | 6. Unterseebootsflottille | 11. Unterseebootsflottille | <b>U-133</b>               |
| 2. Unterseebootsflottille | <b>U-135</b>              | <b>U-1061</b>              | 23. Unterseebootsflottille |
| <b>U-134</b>              | 7. Unterseebootsflottille | 12. Unterseebootsflottille | <b>U-77</b>                |
| 3. Unterseebootsflottille | <b>U-96</b>               | <b>U-293</b>               | 29. Unterseebootsflottille |
|                           | 9. Unterseebootsflottille | 13. Unterseebootsflottille | 81002-001 U-BOOT Typ VII C |

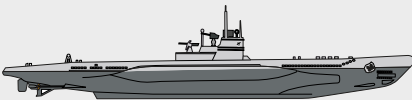

- U-128** 2. U-Flottille  
**U-134** 3. U-Flottille  
**U-67** 5. U-Flottille

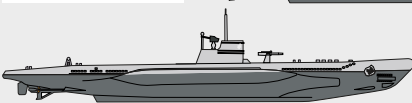

1977 2020

### COLLECTION HISTORIQUE



REF: 81011

### TORPEDOBOOT T23

Scale: 1/400

<b>Année de fabrication</b> Year of construction • Baujahr	1939
<b>Quantité produite</b> Built quantity • Gebaute Menge	15
<b>Puissance</b> Power • Leistung	29.000 CV/PS
<b>Vitesse maximale</b> Max. Speed • Max. Geschwindigkeit	34 knots
<b>Longueur totale</b> Total length • Gesamtlänge	102.50 m

255 x 24 mm 4 x Decorations provided 118 pieces

### COLLECTION HISTORIQUE



REF: 81002

### U-BOOT TYPE VII C

Scale: 1/400

<b>Année de fabrication</b> Year of construction • Baujahr	1935
<b>Quantité produite</b> Built quantity • Gebaute Menge	1.153
<b>Puissance</b> Power • Leistung	3.200 CV/PS (surfaced) / 750 CV/PS (submerged)
<b>Vitesse maximale</b> Max. Speed • Max. Geschwindigkeit	17,7 knots (surfaced) / 7,6 knots (submerged)
<b>Longueur totale</b> Total length • Gesamtlänge	67,10 m

176 x 15,5 mm 14 x Decorations provided 34 pieces

COLLECTION HISTORIQUE



REF: 85009 **MARCEAU + ZERSTÖRER Z31** Scale: 1/400

<b>Année de fabrication</b> Year of construction • Baujahr	1941
<b>Quantité produite</b> Built quantity • Gebaute Menge	7
<b>Puissance</b> Power • Leistung	75.638 CV/PS
<b>Vitesse maximale</b> Max. Speed • Max. Geschwindigkeit	36,5 knots
<b>Longueur totale</b> Total length • Gesamtlänge	127 m

2 x 315 x 29 mm **TWIN SET** 2 x Decorations provided 2 x 163 pieces

**MARCEAU + ZERSTÖRER Z31**

REF: 85009  
Plus d'informations  
More about this product  
Mehr zu diesem Produkt



REF: 55009  
Starter Kit

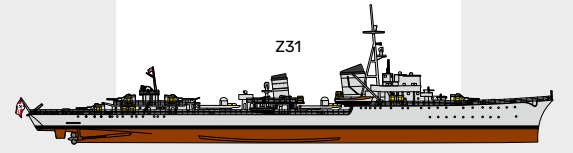
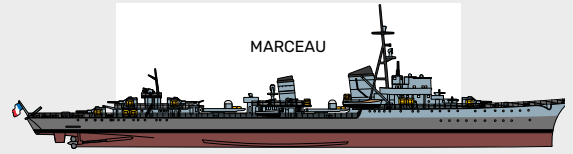
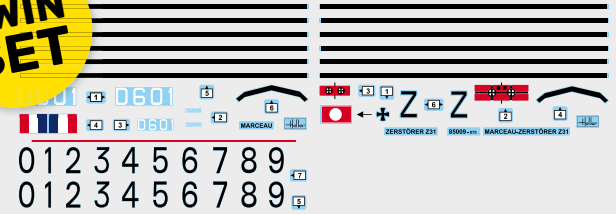

1980 2020

COLLECTION HISTORIQUE



REF: 85050 **LA SEINE + LA SAÔNE** Scale: 1/400

<b>Année de fabrication</b> Year of construction • Baujahr	1939 / 1948
<b>Quantité produite</b> Built quantity • Gebaute Menge	1
<b>Puissance</b> Power • Leistung	15 800 CV/PS
<b>Vitesse maximale</b> Max. Speed • Max. Geschwindigkeit	18 knots
<b>Longueur totale</b> Total length • Gesamtlänge	160 m

2 x 400 x 55 mm **TWIN SET** 2 x Model Kit inclusive 2 x 190 pieces

**LA SEINE + LA SAÔNE**

REF: 85050  
Plus d'informations  
More about this product  
Mehr zu diesem Produkt



REF: 55050  
Starter Kit

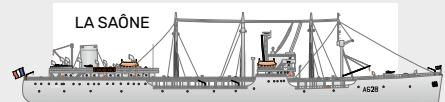
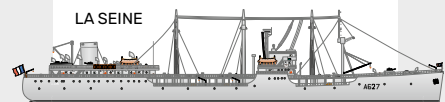
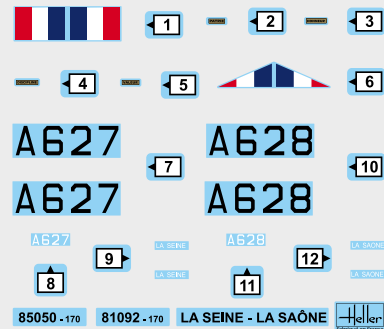

1967 2021

## ESCORTEURS RAPIDES E 50

**REF: 81093**  
Plus d'informations  
More about this product  
Mehr zu diesem Produkt



**REF: 57093**  
Starter Kit



**TWIN SET**

Parts lists for hulls (F761-F764) and superstructures (S1-S11). Includes a 'TWIN SET' badge.

Ship models shown: LE CORSE, LE BRESTOIS, LE BOULONNAIS, LE BORDELAIS.

1977 2022

## ESCORTEURS RAPIDES E 52

**REF: 81094**  
Plus d'informations  
More about this product  
Mehr zu diesem Produkt



**REF: 57094**  
Starter Kit



**TWIN SET**

Parts lists for hulls (F767-F777) and superstructures (S1-S11). Includes a 'TWIN SET' badge.

Ship models shown: LE GASCON, L'ALSACIEN, LE BRETON, LE PROVENCAL.

1977 2022

**Heller**  
COLLECTION HISTORIQUE

REF: 81093  
**ESCORTEURS RAPIDES E 50**  
Scale: 1/400

<b>Année de fabrication</b> Year of construction • Baujahr	1953
<b>Quantité produite</b> Built quantity • Gebaute Menge	4
<b>Puissance</b> Power • Leistung	20.000 CV / PS
<b>Vitesse maximale</b> Max. Speed • Max. Geschwindigkeit	27 kn
<b>Longueur totale</b> Total length • Gesamtlänge	99,8 m

2 x 248 x 26 mm  
TWIN SET  
4 x Decorations provided  
2 x 360 pieces

**Heller**  
COLLECTION HISTORIQUE

REF: 81094  
**ESCORTEURS RAPIDES E 52**  
Scale: 1/400

<b>Année de fabrication</b> Year of construction • Baujahr	1958
<b>Quantité produite</b> Built quantity • Gebaute Menge	14
<b>Puissance</b> Power • Leistung	20.000 CV / PS
<b>Vitesse maximale</b> Max. Speed • Max. Geschwindigkeit	27 kn
<b>Longueur totale</b> Total length • Gesamtlänge	99,8 m

2 x 248 x 26 mm  
TWIN SET  
4 x Decorations provided  
2 x 360 pieces

Heller

COLLECTION HISTORIQUE



**VICTOR SCHOELCHER -  
COMMANDANT RIVIERE**

REF: 81015 Scale: 1/400

<b>Année de fabrication</b> Year of construction • Baujahr	1957 / 1963
<b>Quantité produite</b> Built quantity • Gebaute Menge	9
<b>Puissance</b> Power • Leistung	16 000 CV/PS
<b>Vitesse maximale</b> Max. Speed • Max. Geschwindigkeit	26 knots
<b>Longueur totale</b> Total length • Gesamtlänge	102.70 m

 257 x 29 mm 2 x Decorations provided 129 pieces

**VICTOR SCHOELCHER -  
COMMANDANT RIVIERE**

**REF: 81015**  
Plus d'informations  
More about this product  
Mehr zu diesem Produkt



**REF: 57015**  
Starter Kit



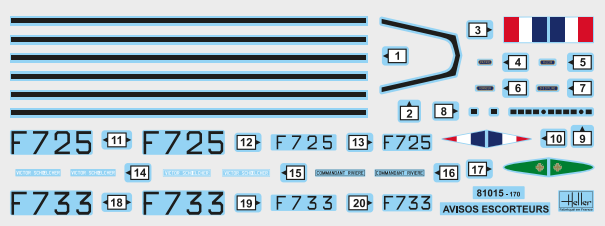

F725 - Victor Schoelcher

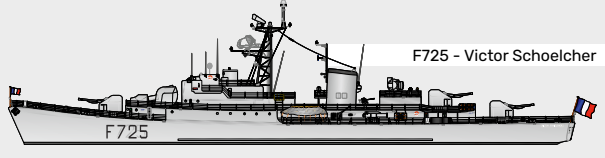

F733 - Commandant Riviere

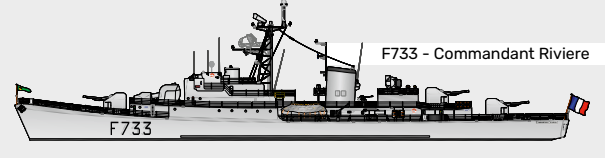

1971 2021

Heller

COLLECTION HISTORIQUE



**JEANNE D'ARC**

REF: 81034 Scale: 1/400

<b>Année de fabrication</b> Year of construction • Baujahr	1961
<b>Quantité produite</b> Built quantity • Gebaute Menge	1
<b>Puissance</b> Power • Leistung	40 000 CV/PS
<b>Vitesse maximale</b> Max. Speed • Max. Geschwindigkeit	27 knots
<b>Longueur totale</b> Total length • Gesamtlänge	181.38 m

 452 x 55 mm 293 pieces

**JEANNE D'ARC**

**REF: 81034**  
Plus d'informations  
More about this product  
Mehr zu diesem Produkt



**REF: 57034**  
Starter Kit



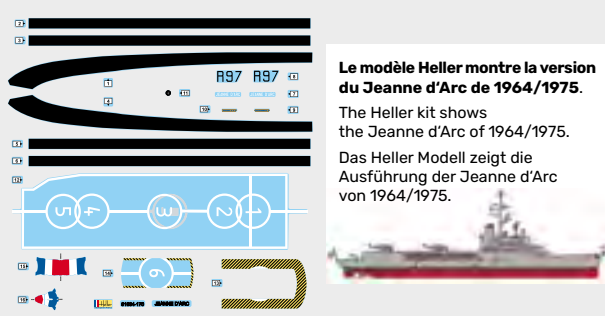

**Le modèle Heller montre la version du Jeanne d'Arc de 1964/1975.**

The Heller kit shows the Jeanne d'Arc of 1964/1975.

Das Heller Modell zeigt die Ausführung der Jeanne d'Arc von 1964/1975.

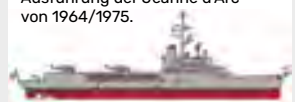
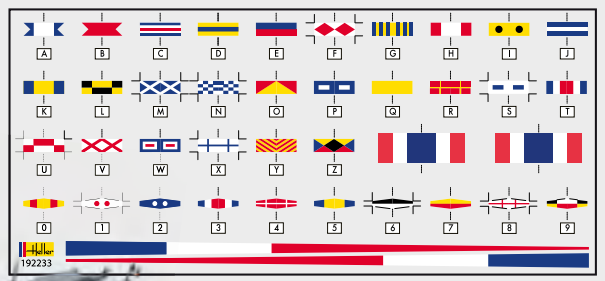
1966 2022

## FOCH 1965

REF: 81071

Plus d'informations  
More about this product  
Mehr zu diesem Produkt



REF: 57071

Starter Kit

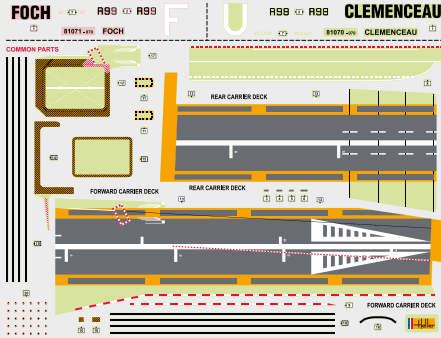

**Le modèle Heller montre la version du Foch de 1965-1969.**  
The Heller kit shows the design of the Foch from 1965-1969.  
Das Heller Modell zeigt die Ausführung der Foch von 1965-1969.

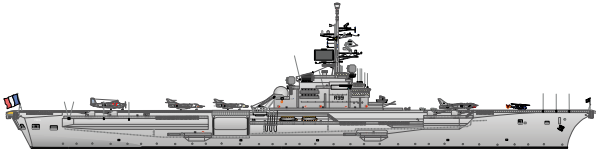

1965 2020

## LE REDOUTABLE

REF: 81075

Plus d'informations  
More about this product  
Mehr zu diesem Produkt



REF: 57075

Starter Kit

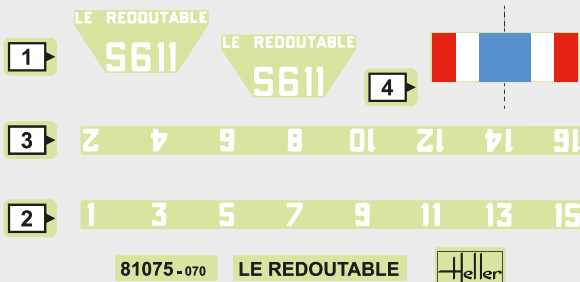

1971 2020

### COLLECTION HISTORIQUE

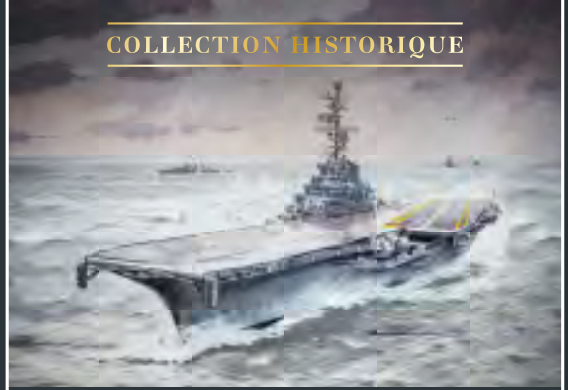

REF: 81071

**FOCH 1965**

Scale: 1/400

**Année de fabrication**

Year of construction • Baujahr

1957 / 1960

**Quantité produite**

Built quantity • Gebaute Menge

1

**Puissance**

Power • Leistung

126.000 CV / PS

**Vitesse maximale**

Max. Speed • Max. Geschwindigkeit

32 knots

**Longueur totale**

Total length • Gesamtlänge

265 m



661 x 128 mm

152 pieces

### COLLECTION HISTORIQUE



REF: 81075

**LE REDOUTABLE**

Scale: 1/400

**Année de fabrication**

Year of construction • Baujahr

1964

**Quantité produite**

Built quantity • Gebaute Menge

1

**Puissance**

Power • Leistung

16.000 CV/PS

**Vitesse maximale**

Max. Speed • Max. Geschwindigkeit

27 knots

**Longueur totale**

Total length • Gesamtlänge

128 m

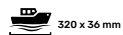

320 x 36 mm

25 pieces

Heller

**COLLECTION HISTORIQUE**



**TASK FORCE RAVITAILLEMENT À LA MER 1968**

REF: 81092 Scale: 1/400

	Foch	La Seine	Dupetit Thouars
<b>Année de fabrication</b> Year of construction · Baujahr	1957 / 1960	1939 / 1948	1952 / 1954
<b>Quantité produite</b> Built quantity · Gebaute Menge	1	1	1
<b>Puissance</b> Power · Leistung	126.000 CV/PS	15.800 CV/PS	63.000 CV/PS
<b>Vitesse maximale</b> Max. Speed · Max. Geschwindigkeit	32 kn	18 kn	32 kn
<b>Longueur totale</b> Total length · Gesamtlänge	265 m	160 m	128 m

3 x  400 x 55 mm  
320 x 32 mm  
661 x 128 mm

8 x Decorations provided

583 pieces

## TASK FORCE RAVITAILLEMENT À LA MER 1968

REF: 81092  
Plus d'informations  
More about this product  
Mehr zu diesem Produkt



REF: 57092  
Starter Kit

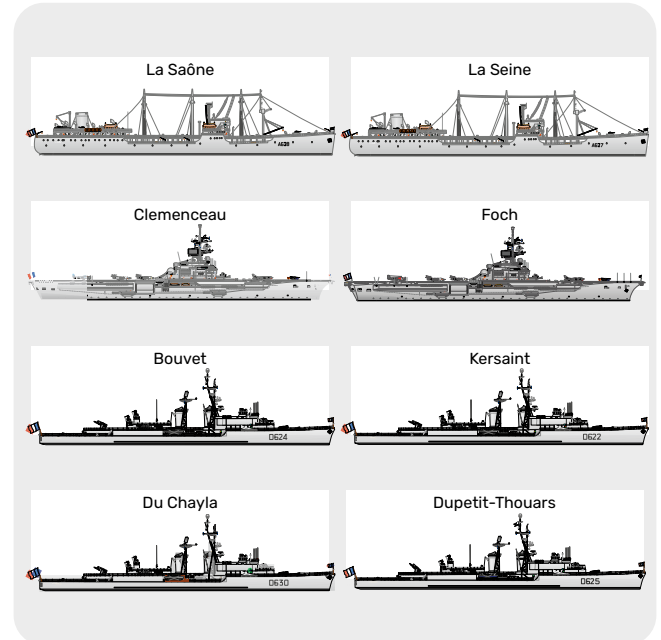

1964 2021 1967 2021 1968 2021

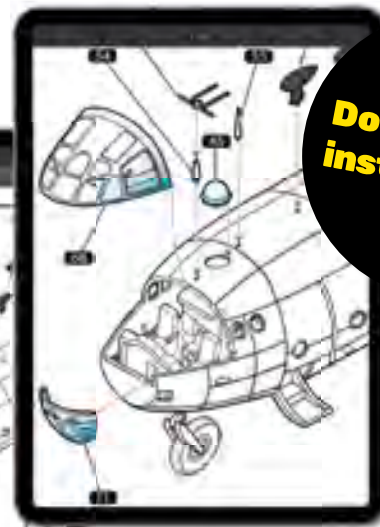

**Download all instructions!**

Choisissez l'article désiré et téléchargez la notice de montage.

Choose your desired article and download the instructions.

Wählen Sie den gewünschten Artikel und laden Sie die Anleitung herunter.

Grossissement des instructions pour une vue détaillée.

Enlarge the instructions for a more detailed view.

Vergrößern Sie die Anleitung für eine detailliertere Ansicht.



# Heller

ADVERTISEMENT

Distributed by  
**GLOW2B**  
germany

REF: 80146  
ALPINE A310 V6

Scale: 1/43

50 Pieces



97 x 38 mm

## THE WILD '70s

REF: 80176  
BERLINE K70

Scale: 1/43

37 Pieces



102 x 39,2 mm







Heller

# VOILIERS

SAILING SHIPS  
SEGELSCHIFFE

# LE SOLEIL ROYAL

**[FRANÇAIS]** Ce modèle est celui du premier des trois vaisseaux de ligne qui ont porté ce nom dans la marine française. Il s'illustra sous Tourville qui y arborait sa marque lors de la victoire de Béveziers le 10 juillet 1690, et à la bataille de Barfleur, le 29 mai 1692. Ce premier Soleil Royal fut construit à Brest en 1669 sur les plans de L. Hubac pour un port initial de 2000 tonneaux, et percé pour 104 canons. Les sculptures qui l'ornaient sont attribuées à Coysevox. Le soleil Royal a fait l'objet de nombreuses recherches de la part des experts en marine ancienne, le Soleil Royal de chacun d'entre eux n'a pu recueillir l'approbation des autres. En fait, les documents authentiques ont disparus. La maquette proposée par HELLER soulèvera bien des passions, elle apportera peut-être quelques éléments nouveaux au dossier toujours ouvert.

**[ENGLISH]** This is a model of the first of the three line ships which bore this name in the royal French navy. She became famous under Tourville who flew his flag on her during the victory of Béveziers on

10th July 1690 and at the battle of Barfleur on 29th May 1692. This first „Soleil Royal“ was built at Brest in 1669 from plans by L. Hubac for an initial tonnage of 2,000 tons, and was designed to take 104 cannon. The sculptures which ornament the ship are attributed to Coysevox. Naval history experts have conducted a great deal of research into the „Soleil Royal“ : they have all come up with their own theories, and they have all disagreed. All authentic documentation has disappeared. The HELLER model aroused great emotion among the experts of the time, even though new elements were added.

**[DEUTSCH]** Bei diesem Modell handelt es sich um das erste von drei Schiffen einer Linie, die diesen Namen in der französischen Marine trugen. Sie zeichnete sich unter Tourville aus, der sie beim Sieg von Béveziers am 10. Juli 1690 und in der Schlacht von Barfleur am 29. Mai 1692, führte. Diese erste Soleil Royal wurde 1669 in Brest nach den Plänen von L. Hubac für eine ursprüngliche Tonnage von 2000 Tonnen gebaut und war für 104 Kanonen ausgelegt. Die Skulpturen, die das Schiff schmückten, wurden Coysevox zugeschrieben. Die Experten für Marinegeschichte hatten die „Soleil Royal“ gründlich erforscht: Sie hatten alle ihre eigenen Theorien aufgestellt und waren sich uneinig. Alle authentischen Dokumente waren verschwunden. Das HELLER Modell löste unter den damaligen Fachleuten große Emotionen aus, auch wenn neue Elemente hinzugefügt wurden.

REF: 80899
**LE SOLEIL ROYAL**
Scale: 1/100

<b>Année de fabrication</b> Year of construction • Baujahr	1669
<b>Vitesse maximale</b> Max. Speed • Max. Geschwindigkeit	10 kn
<b>Longueur totale</b> Total length • Gesamtlänge	77 m

770 x 765 mm
2300 pieces

**MANUEL D'ASSEMBLAGE**  
ASSEMBLY INSTRUCTIONS  
MONTAGEANLEITUNG

**1974** **2021**

**REF: 80899**  
Plus d'informations  
More about this product  
Mehr zu diesem Produkt



**REF: 58899**  
Starter Kit





# HMS VICTORY

**[FRANÇAIS]** La maquette HELLER représente le "HMS Victory" de l'amiral anglais Lord Horatio Nelson, vaisseau à trois ponts de premier rang, qui participa à la bataille de Trafalgar et cinquième navire de la Royal Navy à porter ce nom. C'est le 28 octobre 1760 que le navire reçu officiellement son nom de Victory. En 1777, la Grande Bretagne se trouva en guerre et le 8 mai 1778, le bateau terminé prenait enfin la mer en tant que vaisseau amiral sous les ordres de l'amiral Lord Keppel pour participer à son premier combat naval contre la flotte française, au large d'Ouessant. Placé en cale sèche, le Victory fut presque entièrement reconstruit et lorsqu'en avril 1803, il fut de nouveau armé, son aspect avait beaucoup changé. À sa sortie en mer, à l'issue de toutes ses modifications le Victory présentait un aspect tel que celui que l'on admire encore aujourd'hui.

**[ENGLISH]** The HELLER Model is the English Admiral Lord Horatio Nelson's „H.M.S. Victory“, three-Decker-vessel that was involved in the

Trafalgar battle and is the Royal Navy fifth vessel of that name. On 28th October 1760 the ship was officially named „Victory“. In 1777 Great Britain was at war again and on 8th May 1778 the completed vessel was launched as Admiral Vessel under the command of Admiral Lord Keppel to fight her first battle against the French fleet near the Brittany coast. April 1803 she was armed again, with her appearance very different. Most of the golden ornamentation had been changed, or had been deleted. When she then went back to sea she had the looks that are much admired today.

**[DEUTSCH]** Das HELLER-Modell stellt die „HMS Victory“ des englischen Admirals Lord Horatio Nelson dar, ein Dreideckschiff ersten Ranges, das an der Schlacht von Trafalgar teilnahm und das fünfte Schiff der Royal Navy war, das diesen Namen trug. Am 28. Oktober 1760 wurde das Schiff offiziell auf den Namen Victory getauft. Im Jahr 1777 befand sich Großbritannien im Krieg und am 8. Mai 1778 segelte das Schiff schließlich als Flaggschiff unter Admiral Lord Keppel zur ersten Seeschlacht gegen die französische Flotte vor Ushant (Ouessant). Im Trockendock wurde die Victory erneut bewaffnet und als sie im April 1803 wieder zu Wasser gelassen wurde, hatte sich ihr Aussehen erheblich verändert. Die meisten der goldenen Verzierungen waren verändert oder entfernt worden. Als die Victory wieder in See stach, hatte sie das Aussehen, das heute so bewundert wird.



REF: 80897 **HMS VICTORY** Scale: 1/100

<b>Année de fabrication</b> Year of construction • Baujahr	1778
<b>Quantité produite</b> Built quantity • Gebaute Menge	1
<b>Vitesse maximale</b> Max. Speed • Max. Geschwindigkeit	9 kn
<b>Longueur totale</b> Total length • Gesamtlänge	110 m
 1100 x 698 mm	2107 pieces



**NEW BROCHURE**

**MANUEL D'ASSEMBLAGE**  
ASSEMBLY INSTRUCTIONS  
MONTAGEANLEITUNG

1979 2021

**REF: 80897**  
Plus d'informations  
More about this product  
Mehr zu diesem Produkt



**REF: 58897**  
Starter Kit





Heller



REF: 80815

**NINA**

Scale: 1/75

<b>Année de fabrication</b> Year of construction • Baujahr	between 1487 / 1490
<b>Vitesse maximale</b> Max. Speed • Max. Geschwindigkeit	5 / 7 kn
<b>Longueur totale</b> Total length • Gesamtlänge	15,24 m
 250 x 320 mm	99 pieces

**NINA**

REF: 80815  
Plus d'informations  
More about this product  
Mehr zu diesem Produkt



REF: 56815  
Starter Kit



1969 2020

Heller



REF: 80816

**PINTA**

Scale: 1/75

<b>Année de fabrication</b> Year of construction • Baujahr	1491
<b>Quantité produite</b> Built quantity • Gebaute Menge	1
<b>Puissance</b> Power • Leistung	8 kn
<b>Vitesse maximale</b> Max. Speed • Max. Geschwindigkeit	8 knots (15 km/h)
<b>Longueur totale</b> Total length • Gesamtlänge	22,50 m
 300 x 240 mm	113 pieces

**PINTA**

REF: 80816  
Plus d'informations  
More about this product  
Mehr zu diesem Produkt



REF: 56816  
Starter Kit



1969 2021



## SANTA MARIA

REF: 80865

Plus d'informations  
More about this product  
Mehr zu diesem Produkt



REF: 56865

Starter Kit

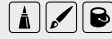

1966 2021

## GOLDEN HIND

REF: 80829

Plus d'informations  
More about this product  
Mehr zu diesem Produkt



REF: 56829

Starter Kit

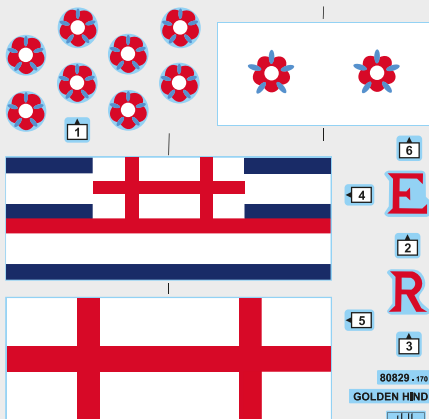

1965 2020

Heller



REF: 80865

SANTA MARIA

Scale: 1/75

**Année de fabrication**

Year of construction • Baujahr

1491

**Vitesse maximale**

Max. Speed • Max. Geschwindigkeit

8 kn (15 km/h)

**Longueur totale**

Total length • Gesamtlänge

25,67 m

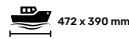

141 pieces

Heller



REF: 80829

GOLDEN HIND

Scale: 1/96

**Année de fabrication**

Year of construction • Baujahr

1575 to 1577

**Vitesse maximale**

Max. Speed • Max. Geschwindigkeit

8 kn (15 km/h)

**Longueur totale**

Total length • Gesamtlänge

31 m

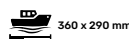

369 pieces

Heller



REF: 80609 **THONIER ARMOR** Scale: 1/125

<b>Année de fabrication</b> Year of construction • Baujahr	1905
<b>Quantité produite</b> Built quantity • Gebaute Menge	870
<b>Puissance</b> Power • Leistung	/
<b>Vitesse maximale</b> Max. Speed • Max. Geschwindigkeit	7 knots
<b>Longueur totale</b> Total length • Gesamtlänge	28,50 m

 228 x 135 mm 89 pieces

Heller



REF: 80895 **LE SUPERBE** Scale: 1/150

<b>Année de fabrication</b> Year of construction • Baujahr	1782 / 1784
<b>Vitesse maximale</b> Max. Speed • Max. Geschwindigkeit	5-14 kn
<b>Longueur totale</b> Total length • Gesamtlänge	85 m

 560 x 450 mm 867 pieces

## THONIER ARMOR

REF: 80609  
Plus d'informations  
More about this product  
Mehr zu diesem Produkt



REF: 56609  
Starter Kit



A<sup>u</sup> 1867

1

A<sup>u</sup> 1867

A<sup>u</sup> 1867

A<sup>u</sup> 1867

2

ARMOR  
MURAY

3



80609 - 170

THONIER ARMOR

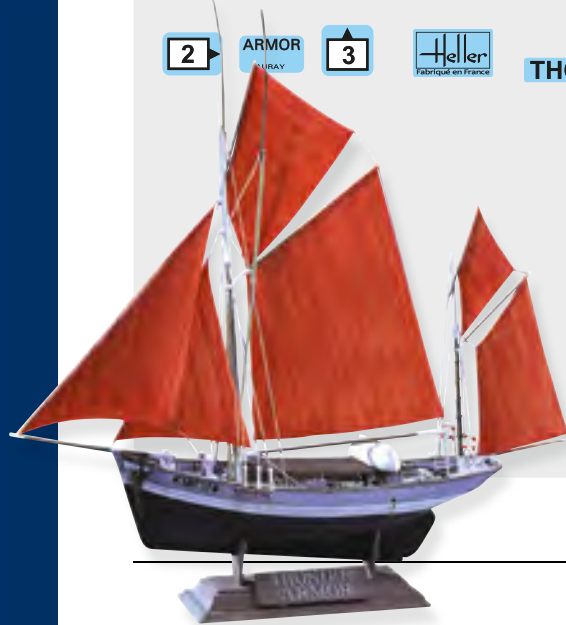

1978 2021

## LE SUPERBE

REF: 80895  
Plus d'informations  
More about this product  
Mehr zu diesem Produkt



REF: 58895  
Starter Kit

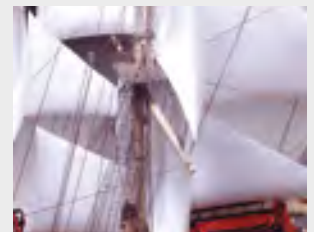

1977 2021

## AMERIGO VESPUCCI

REF: 80807

Plus d'informations  
More about this product  
Mehr zu diesem Produkt



REF: 58807

Starter Kit



80807 - 170

AMERIGO VESPUCCI



AMERICO VESPUCCI



1978 2020

## LA GRANDE HERMINE

REF: 80841

Plus d'informations  
More about this product  
Mehr zu diesem Produkt



REF: 56841

Starter Kit

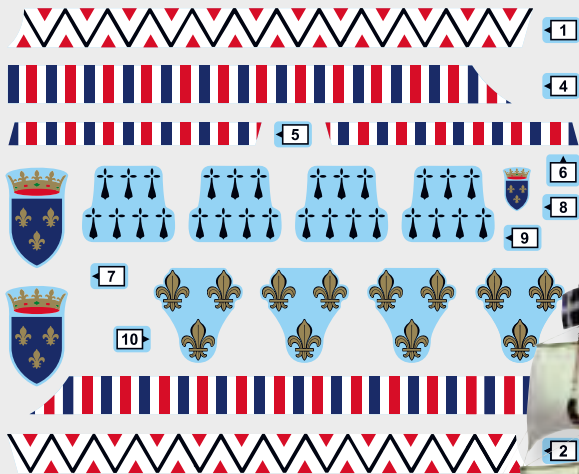

80841 - 170

LA GRANDE HERMINE



1979 2021



REF: 80807

AMERIGO VESPUCCI

Scale: 1/150

**Année de fabrication**

Year of construction • Baujahr

1931

**Vitesse maximale**

Max. Speed • Max. Geschwindigkeit

10 kn

**Longueur totale**

Total length • Gesamtlänge

101 m



700 x 395 mm

409 pieces



REF: 80841

LA GRANDE HERMINE

Scale: 1/150

**Année de fabrication**

Year of construction • Baujahr

1497

**Quantité produite**

Built quantity • Gebaute Menge

1

**Longueur totale**

Total length • Gesamtlänge

47,70 m



318 x 425 mm

126 pieces

Heller



REF: 80889

**LE GLORIEUX**

Scale: 1/150

<b>Année de fabrication</b> Year of construction • Baujahr	1756
<b>Vitesse maximale</b> Max. Speed • Max. Geschwindigkeit	5 - 7 kn
<b>Longueur totale</b> Total length • Gesamtlänge	85 m

560 x 450 mm

870 pieces

**LE GLORIEUX**

**REF: 80889**  
Plus d'informations  
More about this product  
Mehr zu diesem Produkt



**REF: 58889**  
Starter Kit



1978 2020

Heller



REF: 80830

**FLYING CLOUD**

Scale: 1/200

<b>Année de fabrication</b> Year of construction • Baujahr	1851
<b>Poids</b> Weight • Gewicht	1783 t
<b>Longueur totale</b> Total length • Gesamtlänge	70 m

406 x 280 mm

126 pieces

**FLYING CLOUD**

**REF: 80830**  
Plus d'informations  
More about this product  
Mehr zu diesem Produkt



**REF: 56830**  
Starter Kit

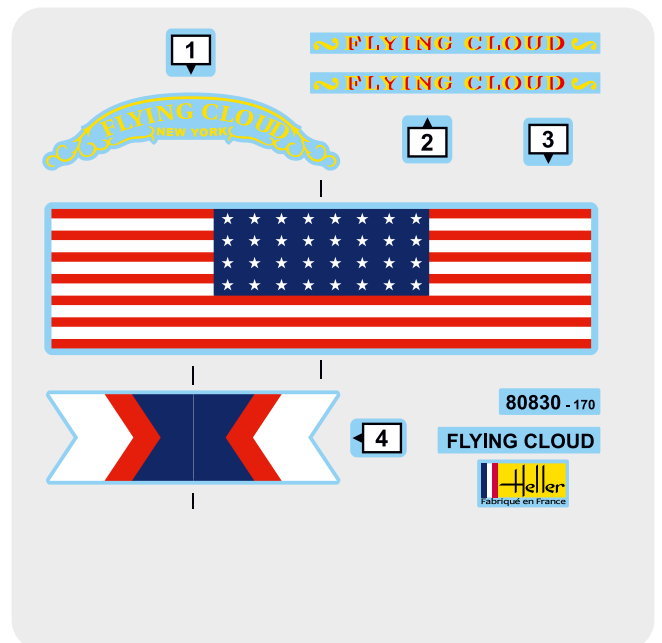

1988 2021

## GALION

REF: 80835

Plus d'informations  
More about this product  
Mehr zu diesem Produkt



REF: 56835

Starter Kit

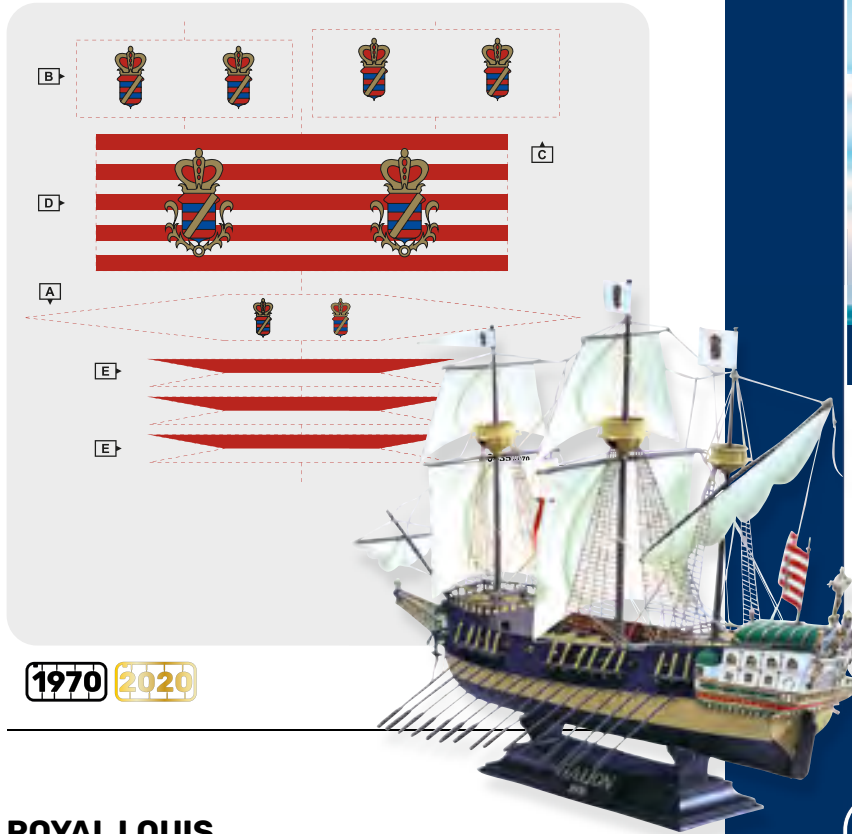

1970 2020



Heller

REF: 80835

GALION

Scale: 1/200

**Année de fabrication**

Year of construction • Baujahr

16th century

**Vitesse maximale**

Max. Speed • Max. Geschwindigkeit

5-7 kn

315 x 250 mm

203 pieces

## ROYAL LOUIS

REF: 80892

Plus d'informations  
More about this product  
Mehr zu diesem Produkt



REF: 58892

Starter Kit

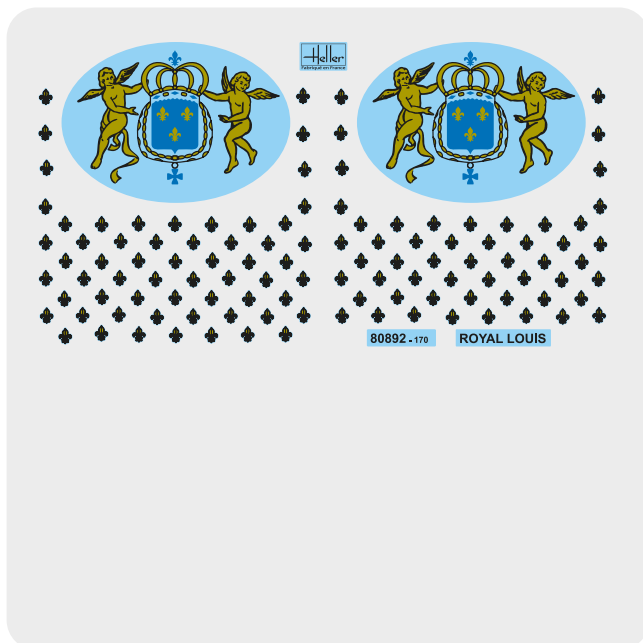

1968 2021



Heller

REF: 80892

ROYAL LOUIS

Scale: 1/200

**Année de fabrication**

Year of construction • Baujahr

1780

**Vitesse maximale**

Max. Speed • Max. Geschwindigkeit

5-7 kn

**Longueur totale**

Total length • Gesamtlänge

96 m

480 x 400 mm

648 pieces





**PUZZLES**

PUZZLE

PUZZLE



REF: 20370 **CANADAIR** Puzzle

<b>Année de fabrication</b> Year of construction · Baujahr	1995
<b>Quantité produite</b> Built quantity · Gebaute Menge	76
<b>Puissance</b> Power · Leistung	2 x 2.380 CV/PS
<b>Vitesse maximale</b> Max. Speed · Max. Geschwindigkeit	376 km/h
<b>Envergure</b> Wing span · Flügelspannweite	28,61 m

 47 x 33 cm 500 pieces

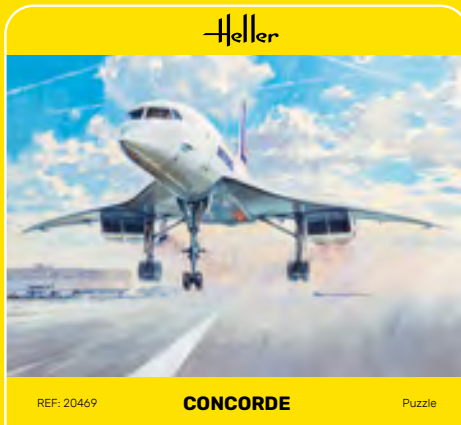

REF: 20469 **CONCORDE** Puzzle

<b>Année de fabrication</b> Year of construction · Baujahr	1967
<b>Quantité produite</b> Built quantity · Gebaute Menge	20
<b>Puissance</b> Power · Leistung	140 kN (dry) / 169,3 kN with afterburner each
<b>Vitesse maximale</b> Max. Speed · Max. Geschwindigkeit	Mach 2,05
<b>Envergure</b> Wing span · Flügelspannweite	25,60 m

 68 x 47 cm 1500 pieces



REF: 20510 **FOUGA MAGISTER** Puzzle

<b>Année de fabrication</b> Year of construction · Baujahr	1953
<b>Quantité produite</b> Built quantity · Gebaute Menge	1 009
<b>Puissance</b> Power · Leistung	480 kgp x 2
<b>Vitesse maximale</b> Max. Speed · Max. Geschwindigkeit	725 km/h
<b>Envergure</b> Wing span · Flügelspannweite	12,15 m

 68 x 47 cm 1000 pieces

**REF: 20370**  
Plus d'informations  
More about this product  
Mehr zu diesem Produkt



**REF: 20469**  
Plus d'informations  
More about this product  
Mehr zu diesem Produkt



**REF: 20510**  
Plus d'informations  
More about this product  
Mehr zu diesem Produkt



REF: 20620 **SMIT ROTTERDAM** Puzzle

<b>Année de fabrication</b> Year of construction · Baujahr	1975
<b>Quantité produite</b> Built quantity · Gebaute Menge	2
<b>Puissance</b> Power · Leistung	22.000 CV/PS
<b>Vitesse maximale</b> Max. Speed · Max. Geschwindigkeit	15,5 kn
<b>Portée en jours</b> Range in days · Reichweite in Tagen	20 days in transit

 68 x 47 cm 1000 pieces



REF: 20897 **HMS VICTORY** Puzzle

<b>Année de fabrication</b> Year of construction · Baujahr	1778
<b>Longueur totale</b> Total length · Gesamtlänge	110 m
<b>Vitesse maximale</b> Max. Speed · Max. Geschwindigkeit	9 kn

 47 x 68 cm 1500 pieces

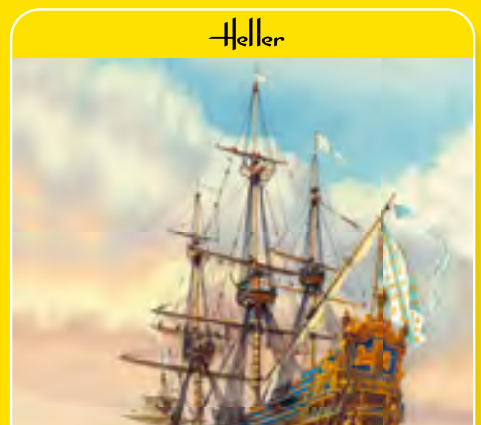

REF: 20899 **SOLEIL ROYAL** Puzzle

<b>Année de fabrication</b> Year of construction · Baujahr	1669
<b>Vitesse maximale</b> Max. Speed · Max. Geschwindigkeit	10 kn
<b>Longueur totale</b> Total length · Gesamtlänge	77 m

 47 x 68 cm 1500 pieces

**REF: 20620**  
Plus d'informations  
More about this product  
Mehr zu diesem Produkt



**REF: 20897**  
Plus d'informations  
More about this product  
Mehr zu diesem Produkt



**REF: 20899**  
Plus d'informations  
More about this product  
Mehr zu diesem Produkt







REF: 20705 **RENAULT TAXI DE PARIS** Puzzle

<b>Année de fabrication</b> Year of construction • Baujahr	1907
<b>Quantité produite</b> Built quantity • Gebaute Menge	10.000
<b>Puissance</b> Power • Leistung	10 CV/PS
<b>Vitesse maximale</b> Max. Speed • Max. Geschwindigkeit	45 km/h
<b>Longueur totale</b> Total length • Gesamtlänge	3,75 m

47 x 33 cm 500 pieces

**REF: 20705**  
Plus d'informations  
More about this product  
Mehr zu diesem Produkt



REF: 20743 **RENAULT ESTAFETTE** Puzzle

<b>Année de fabrication</b> Year of construction • Baujahr	1964 / 1973
<b>Quantité produite</b> Built quantity • Gebaute Menge	500.000
<b>Puissance</b> Power • Leistung	45 CV/PS
<b>Vitesse maximale</b> Max. Speed • Max. Geschwindigkeit	90 km/h
<b>Longueur totale</b> Total length • Gesamtlänge	4,1 m

47 x 33 cm 500 pieces

**REF: 20743**  
Plus d'informations  
More about this product  
Mehr zu diesem Produkt



REF: 20759 **RENAULT 4L** Puzzle

<b>Année de fabrication</b> Year of construction • Baujahr	1961
<b>Quantité produite</b> Built quantity • Gebaute Menge	8.135.424
<b>Puissance</b> Power • Leistung	34 CV/PS
<b>Vitesse maximale</b> Max. Speed • Max. Geschwindigkeit	122 km/h
<b>Longueur totale</b> Total length • Gesamtlänge	3,67 m

47 x 33 cm 500 pieces

**REF: 20759**  
Plus d'informations  
More about this product  
Mehr zu diesem Produkt

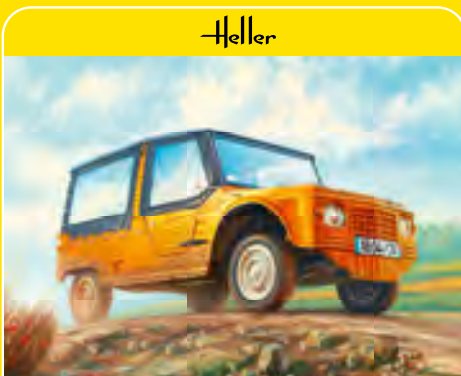

REF: 20760 **CITROËN MEHARI** Puzzle

<b>Année de fabrication</b> Year of construction • Baujahr	1968
<b>Quantité produite</b> Built quantity • Gebaute Menge	144.953
<b>Puissance</b> Power • Leistung	29 CV/PS
<b>Vitesse maximale</b> Max. Speed • Max. Geschwindigkeit	110 km/h
<b>Longueur totale</b> Total length • Gesamtlänge	3,50 m

47 x 33 cm 500 pieces

**REF: 20760**  
Plus d'informations  
More about this product  
Mehr zu diesem Produkt



REF: 20763 **CITROËN 15** Puzzle

<b>Année de fabrication</b> Year of construction • Baujahr	1938
<b>Quantité produite</b> Built quantity • Gebaute Menge	759.111 (total)
<b>Puissance</b> Power • Leistung	77 CV/PS
<b>Vitesse maximale</b> Max. Speed • Max. Geschwindigkeit	130 km/h
<b>Longueur totale</b> Total length • Gesamtlänge	4,80 m

47 x 33 cm 500 pieces

**REF: 20763**  
Plus d'informations  
More about this product  
Mehr zu diesem Produkt



REF: 20766 **CITROËN 2CV** Puzzle

<b>Année de fabrication</b> Year of construction • Baujahr	1980
<b>Quantité produite</b> Built quantity • Gebaute Menge	5.114.961 (total 2CV)
<b>Puissance</b> Power • Leistung	29 CV/PS
<b>Vitesse maximale</b> Max. Speed • Max. Geschwindigkeit	120 km/h
<b>Longueur totale</b> Total length • Gesamtlänge	3,83 m

47 x 33 cm 500 pieces

**REF: 20766**  
Plus d'informations  
More about this product  
Mehr zu diesem Produkt



	<b>002</b>	Vert émeraude brillant	Emerald Green Gloss	Smaragdgrün glänzend		<b>052</b>	Bleu baltique métallique	Baltic Blue Metallic	Baltischblau metallisch
	<b>003</b>	Vert brunswick brillant	Brunswick Green Gloss	Dunkelgrün glänzend		<b>053</b>	Gris métallique	Gunmetal Metallic	Grau metallisch
	<b>005</b>	Gris fonce brillant	Dark Admiralty Grey Gloss	Dunkelgrau glänzend		<b>056</b>	Aluminium métallique	Aluminium Metallic	Aluminium metallisch
	<b>009</b>	Marron clair brillant	Tan Gloss	Holz Braun glänzend		<b>060</b>	Ecarlate mat	Scarlet Matt	Scharlachrot matt
	<b>010</b>	Marron armée brillant	Service Brown Gloss	Dunkelbraun glänzend		<b>061</b>	Chair mat	Flesh Matt	Hautfarbe matt
	<b>011</b>	Argent métallique	Silver Metallic	Silber metallisch		<b>062</b>	Cuir mat	Leather Matt	Leder matt
	<b>012</b>	Cuivre jaune métallique	Copper Metallic	Kupfer metallisch		<b>063</b>	Sable mat	Sand Matt	Sand matt
	<b>014</b>	Bleu de France brillant	French Blue Gloss	Französischblau glänzend		<b>064</b>	Gris clair mat	Light Grey Matt	Hellgrau matt
	<b>015</b>	Bleu nuit brillant	Midnight Blue Gloss	Mitternachtsblau glänzend		<b>065</b>	Bleu avion mat	Aircraft Blue Matt	Flugzeugblau matt
	<b>016</b>	Or métallique	Gold Metallic	Gold metallisch		<b>066</b>	Gris brun olive mat	Olive Drab Matt	Olivgrün matt
	<b>018</b>	Orange brillant	Orange Gloss	Orange glänzend		<b>069</b>	Jaune brillant	Yellow Gloss	Gelb glänzend
	<b>019</b>	Rouge vif brillant	Bright Red Gloss	Hellrot glänzend		<b>070</b>	Rouge brique mat	Brick Red Matt	Ziegelrot matt
	<b>020</b>	Bordeaux brillant	Crimson Gloss	Bordeauxrot glänzend		<b>071</b>	Chêne satiné	Oak Satin	Eichengrün seidenmatt
	<b>021</b>	Noir brillant	Black Gloss	Schwarz glänzend		<b>073</b>	Lie de vin mat	Wine Matt	Weinrot matt
	<b>022</b>	Blanc brillant	White Gloss	Weiß glänzend		<b>077</b>	Bleu marine mat	Navy Blue Matt	Marineblau matt
	<b>024</b>	Jaune entraînement mat	Trainer Yellow Matt	Trainergelb matt		<b>080</b>	Vert pré mat	Grass Green Matt	Grasgrün matt
	<b>025</b>	Bleu mat	Blue Matt	Blau matt		<b>081</b>	Jaune pâle mat	Pale Yellow Matt	Blassgelb matt
	<b>027</b>	Gris mer mat	Sea Grey Matt	Seegrau matt		<b>085</b>	Noir de charbon satiné	Coal Black Satin	Kohlenschwarz seidenmatt
	<b>029</b>	Terre foncée mat	Dark Earth Matt	Erdbraun matt		<b>086</b>	Olive clair mat	Light Olive Matt	Olivgrün hell matt
	<b>030</b>	Vert fonce mat	Dark Green Matt	Dunkelgrün matt		<b>087</b>	Gris acier mat	Steel Grey Matt	Stahlgrau matt
	<b>033</b>	Noir mat	Black Matt	Schwarz matt		<b>089</b>	Bleu moyen mat	Middle Blue Matt	Mittelblau matt
	<b>034</b>	Blanc mat	White Matt	Weiß matt		<b>090</b>	Vert beige mat	Beige Green Matt	Beigegrün matt
	<b>035</b>	Vernis brillant	Clear Poly Gloss	Klarlack glänzend		<b>091</b>	Vert noir mat	Black Green Matt	Schwarzgrün matt
	<b>040</b>	Gris pâle brillant	Pale Grey Gloss	Blassgrau glänzend		<b>092</b>	Gris fer mat	Iron Grey Matt	Eisengrau matt
	<b>041</b>	Ivoire brillant	Ivory Gloss	Elfenbein glänzend		<b>093</b>	Jaune désert mat	Desert Yellow Matt	Wüstensand matt
	<b>049</b>	Vernis mat	Varnish Matt	Klarlack matt		<b>096</b>	Bleu RAF mat	Raf Blue Matt	RAF Blau matt

	<b>098</b>	Chocolat mat	Chocolate Matt	Schokolade matt
	<b>099</b>	Jaune citron mat	Lemon Matt	Zitronengelb matt
	<b>101</b>	Vert moyen mat	Mid Green Matt	Mittelgrün matt
	<b>102</b>	Vert armee mat	Army Green Matt	Armeegrün matt
	<b>103</b>	Creme mat	Cream Matt	Creme matt
	<b>106</b>	Gris ocean mat	Ocean Grey Matt	Ozeangrau matt
	<b>110</b>	Bois naturel mat	Natural Wood Matt	Naturholz matt
	<b>113</b>	Rouille mat	Rust Matt	Rost matt
	<b>116</b>	Vert fonce US mat	US Dark Green Matt	US-Dunkelgrün matt
	<b>119</b>	Terre claire mat	Light Earth Matt	Erde hell matt
	<b>127</b>	Gris fantome US satin	US Ghost Grey Satin	US-Schatten-grau seidenmatt
	<b>130</b>	Blanc satin	White Satin	Weiß seidenmatt
	<b>186</b>	Brun mat	Brown Matt	Braun matt
	<b>321</b>	Rouge transparent	Red Transparent	Rot transparent
	<b>322</b>	Orange transparent	Orange Transparent	Orange transparent
	<b>325</b>	Vert transparent	Green Transparent	Grün transparent

**[FR]** Les peintures acryliques Heller sont excellentes à utiliser et respectueuses de l'environnement. Elles sont le complément idéal de nos kits de construction. Chaque pot contient 12 ml de peinture.

**[EN]** Heller acrylic paints are excellent to work with and environmentally friendly. They are the ideal complement to our kits. Each can contains 12 ml of paint.

**[DE]** Heller Acrylfarben sind hervorragend zu verarbeiten und umweltfreundlich. Sie sind die ideale Ergänzung zu unseren Bausätzen. Jede Dose enthält 12 ml Farbe.



PINCEAU N°3/0  
REF: 9798

PINCEAU N°3  
REF: 9803

PINCEAU N°6  
REF: 9806

PINCEAU PLAT N°10  
REF: 9850

BLISTER PINCEAUX N° 3/0-3-6-10  
REF: 9901

# Heller

Distributed by  
**GLOW2B**  
germany



## LET'S HAVE A BLAST IN 2023! A firework of Heller novelties

Discover our presentation on YouTube



Global Distributor **GLOW2B** [www.glow2b.de](http://www.glow2b.de)

1000965230

